

FlexFilter 13 and 18 cartridge dust collector

High vacuum filter used in application with a working vacuum of max. 40.000 Pa (5,80 psi)



The filters are made in galvanised steel sheet and is bolted together, which makes it a very competitive alternative to other high vacuum filters.

The FlexFilter 13 and 18 can be used in applications where there is a high content of dry dust particles.

The filter can be supplied with either cartridges (UniClean) or cassettes depending on the air flow, the dust type and the dust concentration. The MHFV filter can be delivered in two different heights - type 1300 and 1800.

The cartridges/cassettes are cleaned automatically by a high-efficiency, low energy consuming compressed air system activated by an integral electronic controller.

- Easy to maintain
- Quick release waste bin
- Inspection and change of the filter elements can take place within a few minutes
- Front service of the cleaning valves, the controller, the compressed air tank and the filter elements
- Available with cartridges or cassettes

Nom du produit	FlexFilter 13 and 18 cartridge dust collector
Exigences relatives à l'air comprimé	6 bar
Installation	Intérieur, Extérieur
Matériel	Housing in galvanised steel sheet (4 mm)
Méthode de décolmatage	Jet d'air pulsé
Application	Poussière, Granulé, Abrasif, Fumée
Pression de fonctionnement (kPa)	Max. 40.000 (5,80 psi)
Volume du seau (l)	50 or 100, or whitout
Operating Temperature	-20 to 75 Deg. C.



Granulé Abrasif Fumée Poussière

FlexFilter 13 and 18 cartridge dust collector

FlexFilter 13 and 18 cartridge dust collector

	[accessory]	[partno]
	Adaptor for bin with bag	5505033
	Adaptor for 50 l bin with bag incl. fitting	5505034
	Hose set for bin balancing	5505041
	Isolation box for FM pressure tank, 2 modules	5501317
	Isolation box for FM pressure tank, 4 modules	5501318
	Isolation box for FM pressure tank, 6 modules	5501319
	Isolation box for FM pressure tank, 6 modules	5501320

FlexFilter 13 and 18 cartridge dust collector

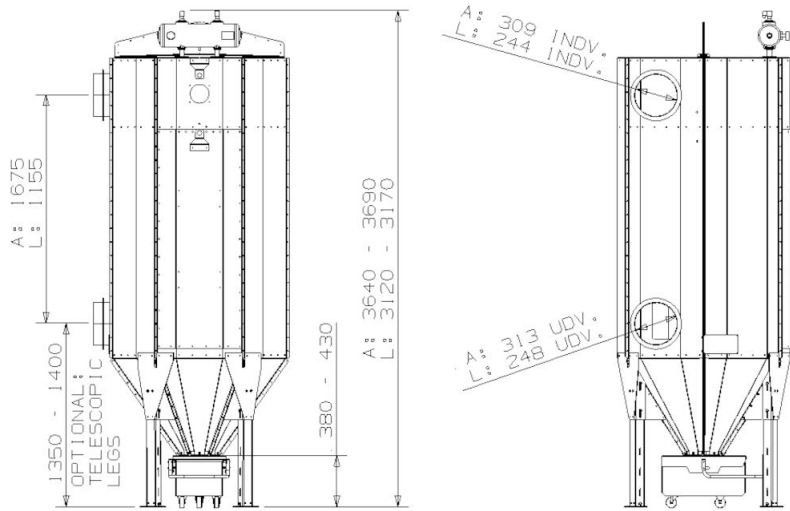

FlexFilter 13 L/A with 50 l bin with wheel

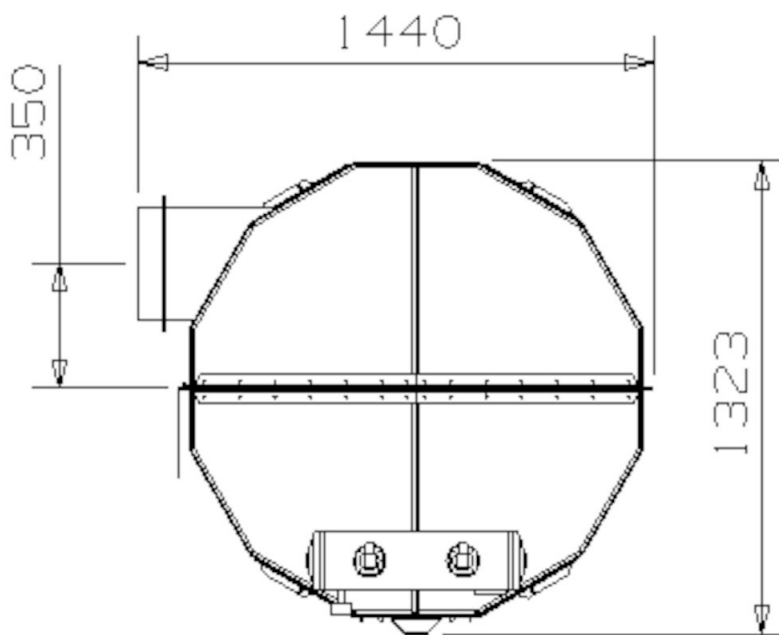

FlexFilter 13 L/A from above.

FlexFilter 13 and 18 cartridge dust collector

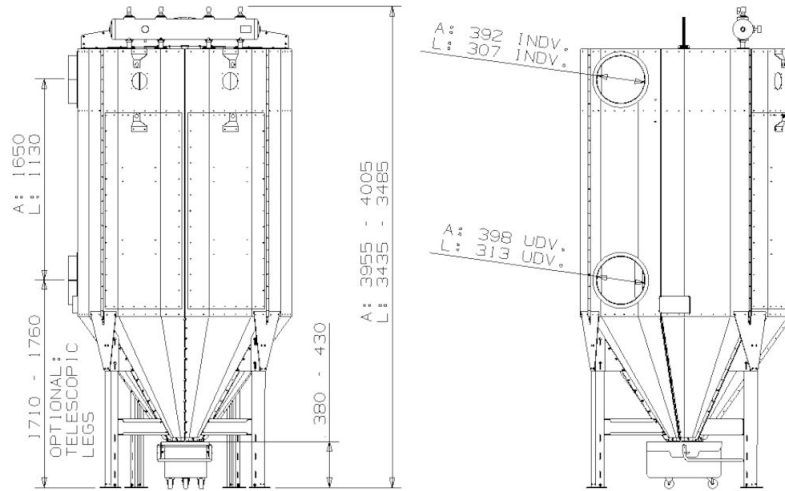

FlexFilter 18 L/A with bin 50 l with wheel

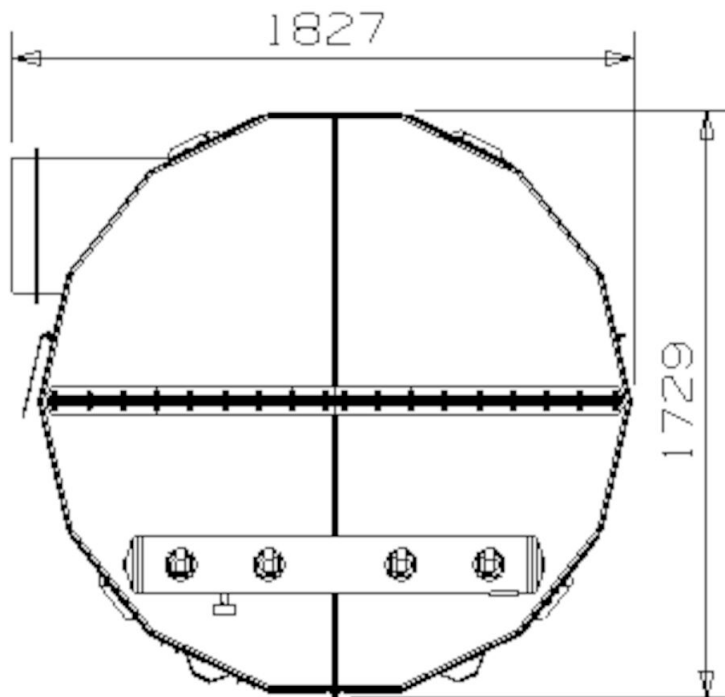

FlexFilter 18 L/A from above

FlexFilter 13 and 18 cartridge dust collector

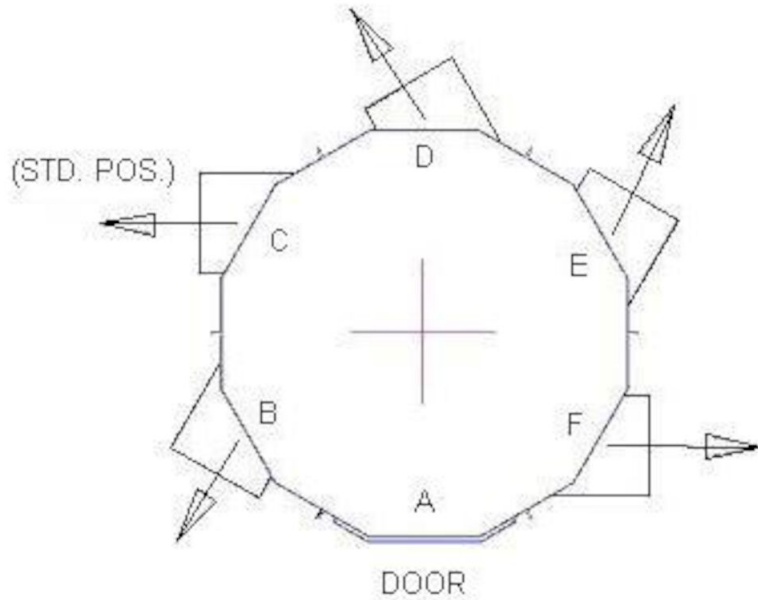

Outlet position for FlexFilter 13 L/A

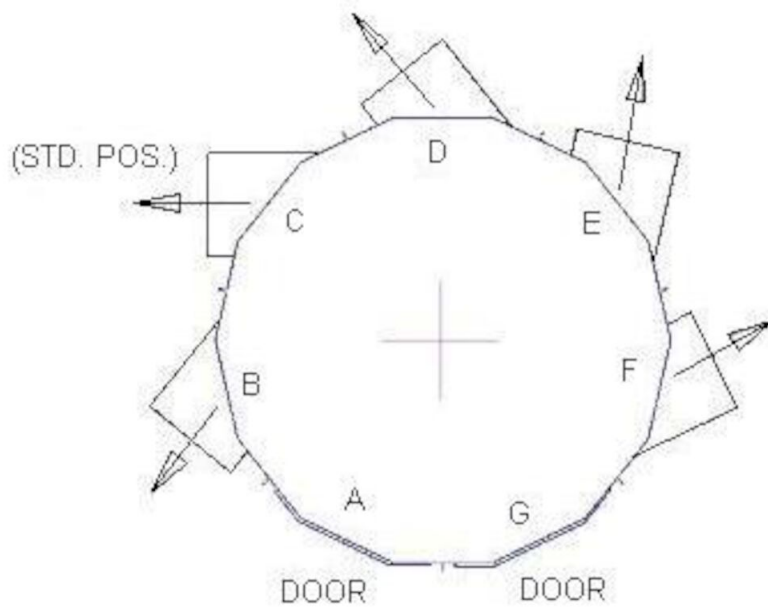

Outlet position, FlexFilter 18 L/A