

FlexFilter 13 and 18 cartridge dust collector

High vacuum filter used in application with a working vacuum of max. 40.000 Pa (5,80 psi)



The filters are made in galvanised steel sheet and is bolted together, which makes it a very competitive alternative to other high vacuum filters.

The FlexFilter 13 and 18 can be used in applications where there is a high content of dry dust particles.

The filter can be supplied with either cartridges (UniClean) or cassettes depending on the air flow, the dust type and the dust concentration. The MHFV filter can be delivered in two different heights - type 1300 and 1800.

The cartridges/cassettes are cleaned automatically by a high-efficiency, low energy consuming compressed air system activated by an integral electronic controller.

Easy to maintain

Quick release waste bin

Inspection and change of the filter elements can take place within a few minutes

Front service of the cleaning valves, the controller, the compressed air tank and the filter elements

Available with cartridges or cassettes











品名	FlexFilter 13 and 18 cartridge dust collector
压缩空气需求	6 bar
安装	室内, 室外
材料	Housing in galvanised steel sheet (4 mm)
清灰方式	脉冲清灰
应用	粉尘, 颗粒物, 沙砾, 烟气
工作压力 (干帕)	Max. 40.000 (5,80 psi)
灰斗容量	50 or 100, or whitout
工作温度	-20 to 75 Deg. C.



FlexFilter 13 and 18 cartridge dust collector

滤芯数量	产品编号
8	13-C-L
8	13-C-A
16	18-C-L
16	18-C-A
2	13-K-L-4
2	13-K-L-6
4	18-K-L-4
4	18-K-L-6

FlexFilter 13 and 18 cartridge dust collector

附件		产品编号
	Discharge bin 50 l without wheels	5501273
	Discharge bin 50 l with wheels	5501274
	Discharge bin 100 l with wheels	5501275
	Adaptor for bin with bag	5505033
	Adaptor for 50 l bin with bag incl. fitting	5505034
	Adaptor for 100 l bin with bag incl. fitting	5505035
	Hose set for bin balancing	5505041
	Isolation box for FM pressure tank, 2 modules	5501317
	Isolation box for FM pressure tank, 4 modules	5501318
	Isolation box for FM pressure tank, 6 modules	5501319
	Isolation box for FM pressure tank, 6 modules	5501320

FlexFilter 13 and 18 cartridge dust collector

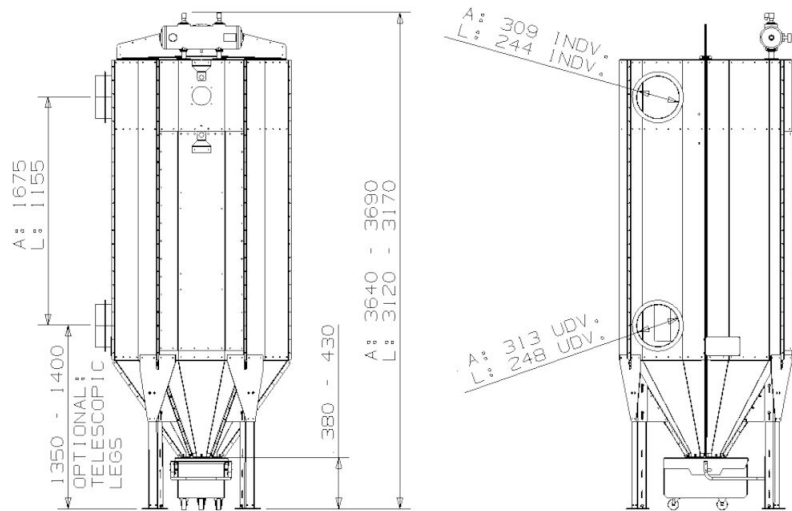

FlexFilter 13 L/A with 50 l bin with wheel

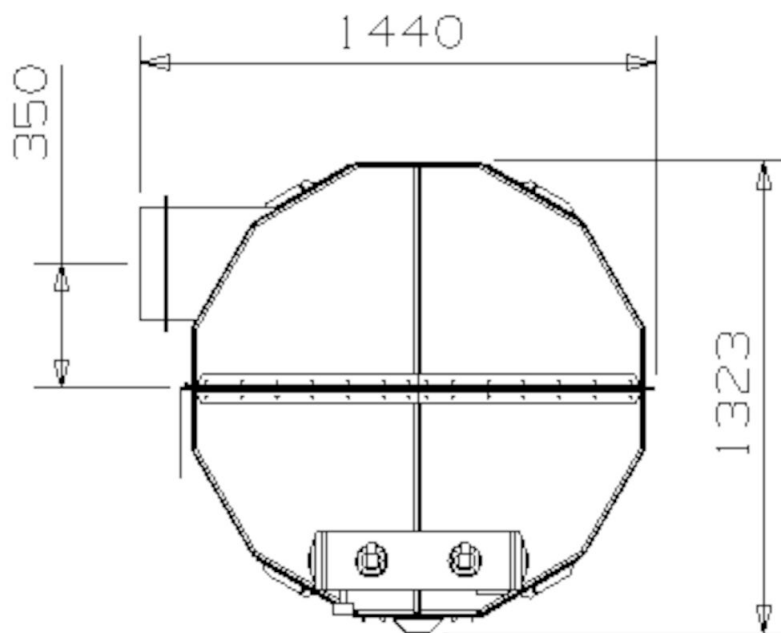

FlexFilter 13 L/A from above.

FlexFilter 13 and 18 cartridge dust collector

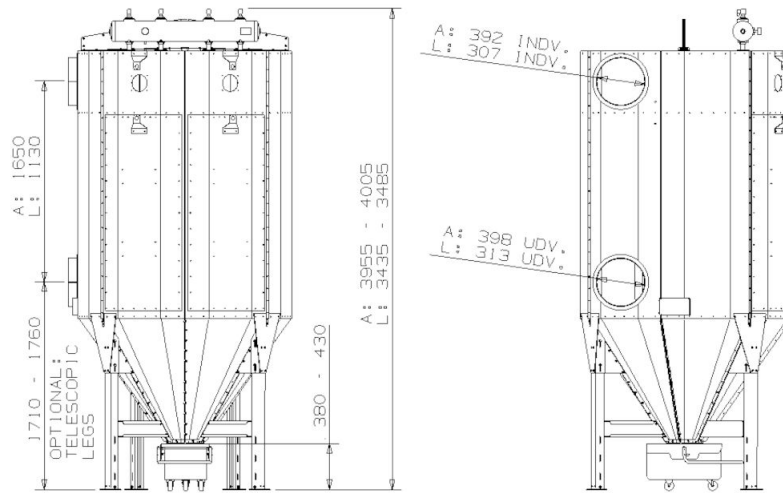

FlexFilter 18 L/A with bin 50 l with wheel

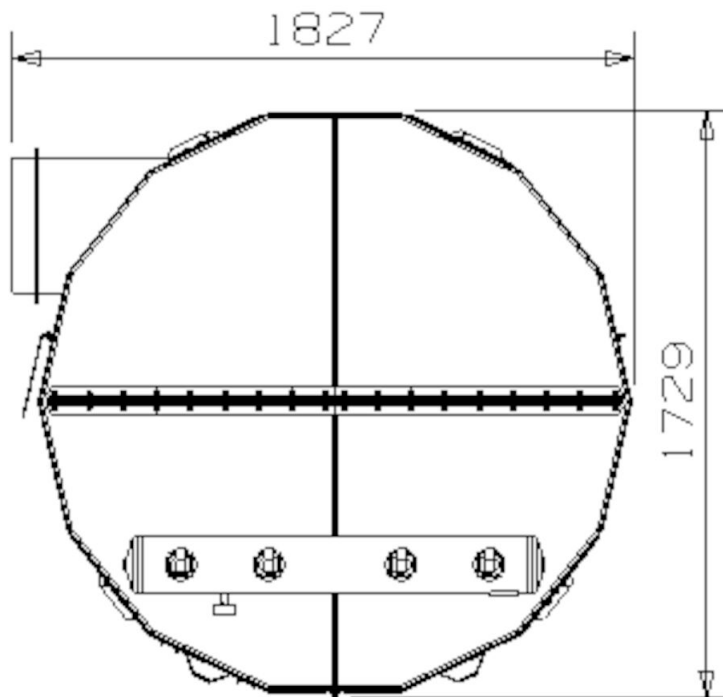

FlexFilter 18 L/A from above

FlexFilter 13 and 18 cartridge dust collector

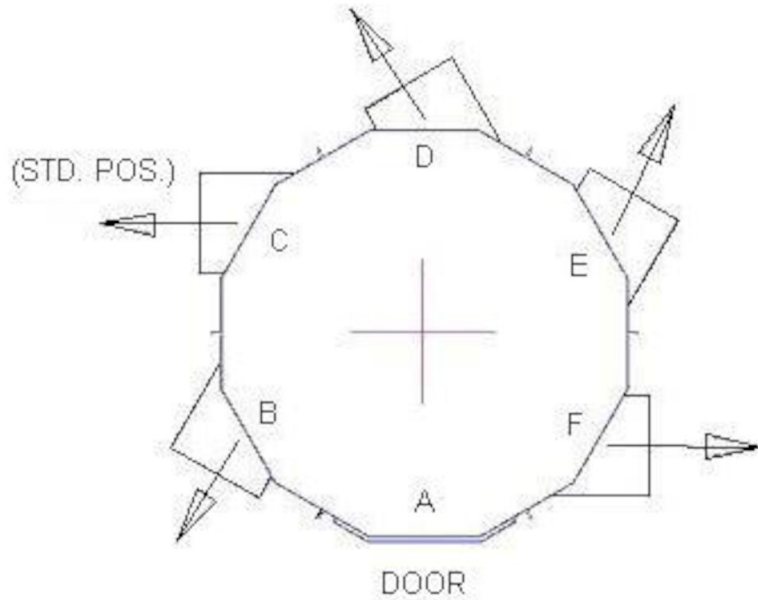

Outlet position for FlexFilter 13 L/A

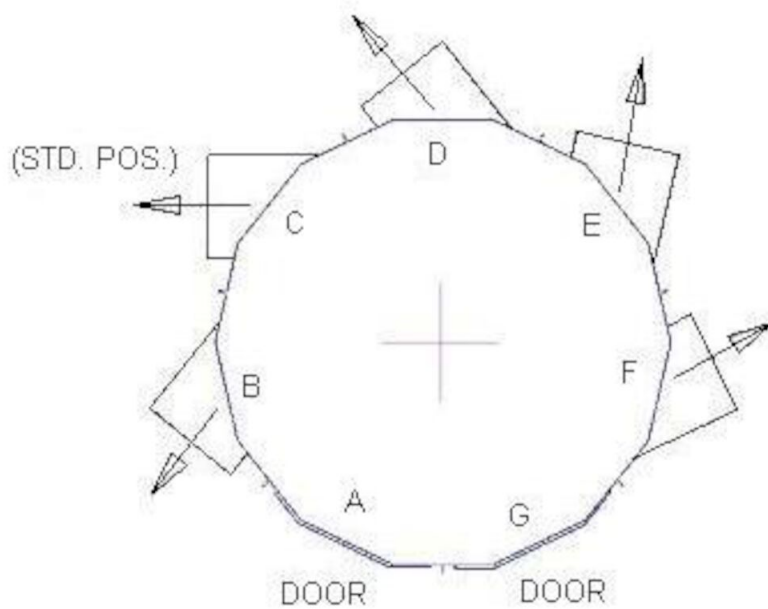

Outlet position, FlexFilter 18 L/A