

## FMKZ cassette filter, EX

Modular cassette dust collector, built for continuous use in industrial process filtration and dust collection applications



The FMK25 range is a reverse jet cassette dust collector. It was built for continuous use in industrial process filtration and dust collection applications. The FMK dust collector uses our long established fabric pocket cassette that is easily maintained through the front hinged doors. The cassette offers ample filter area and lasts longer than a cartridge.

Air Volume Range: 1.700 to 10.000 m<sup>3</sup>/hr (1,000 to 6,000 CFM)

Independently tested (FMKZ) with ATEX compliant features for explosive dusts

Tough galvanised steel construction.

Weatherproof for exposed locations.

Integral pre-separation chamber.

All maintenance from unit front.

Efficient cross flow / down flow inlet air pattern.

Wide range of integral or remote fans.

Bulk materials handling - conveying, screening, sieving, mixing, bin/silo venting

Building materials manufacture and distribution

Building materials manufacture and distribution

Processes with light or medium dust loading

品名	FMKZ cassette filter, EX
安装	室内, 室外
材料	Housing in galvanised sheet steel (2 mm)
适用于易爆粉尘	True
应用	粉尘, 烟气
灰斗容量	50 or 100 l or whitout
工作温度	-20 to 70 Deg. C.
除尘器类型	滤桶式过滤器
滤芯	Polyester
控制电压 (V)	230V / 110V



烟气



粉尘







# FMKZ cassette filter, EX

产品名称	滤芯数量	重量 (公斤)	产品编号
FMKZ25 – 2E with bin for discharge	4	232 (incl. 50l bin excl. fan)	FMKZ25-2Eb(4)
FMKZ25 – 2E with bin for discharge	6	235 (incl. 50l bin excl. fan)	FMKZ25-2Eb(6)
FMKZ25 – 4E with bin for discharge	4	423 (incl. 50l bin excl. fan)	FMKZ25-4Eb(4)
FMKZ25 – 4E with bin for discharge	6	430 (incl. 50l bin excl. fan)	FMKZ25-4Eb(6)
FMKZ25 – 6E with bin for discharge	4	655 (incl. 50l bin excl. fan)	FMKZ25-6Eb(4)
FMKZ25 – 6E with bin for discharge	6	665 (incl. 50l bin excl. fan)	FMKZ25-6Eb(6)
FMKZ25 – 8E with bin for discharge	4	845 (incl. 50l bin excl. fan)	FMKZ25-8Eb(4)
FMKZ25 – 8E with bin for discharge	6	860 (incl. 50l bin excl. fan)	FMKZ25-8Eb(6)
FMKZ25 – 2E hopper with flange for discharge	4	212 (excl. fan)	FMKZ25-2Ef(4)
FMKZ25 – 4E hopper with flange for discharge	4	403 (excl. fan)	FMKZ25-4Ef(4)
FMKZ25 – 4E hopper with flange for discharge	6	410 (excl. fan)	FMKZ25-4Ef(6)
FMKZ25 – 6E hopper with flange for discharge	4	615 (excl. fan)	FMKZ25-6Ef(4)
FMKZ25 – 6E hopper with flange for discharge	6	625 (excl. fan)	FMKZ25-6Ef(6)
FMKZ25 – 6E hopper with flange for discharge	4	805 (excl. fan)	FMKZ25-8Ef(4)
FMKZ25 – 6E hopper with flange for discharge	6	820 (excl. fan)	FMKZ25-8Ef(6)

## FMKZ cassette filter, EX

	附件	产品编号
	Damper type NFUS3	5501395
	Discharge bin 50 l with wheels	5501274
	Discharge bin 50 l without wheels	5501273
	Discharge bin 100 l with wheels	5501275
	Adaptor for bin with bag	5505033
	Adaptor for 50 l bin with bag incl. fitting	5505034
	Adaptor for 100 l bin with bag incl. fitting	5505035
	Hose set for bin balancing	5505041
	Single backpack for 4 modules	5509660
	Single backpack for 4 modules round inlet from the top	5501138
	Single backpack for 8 modules round inlet from the top pos L	5501169
	Double backpack for 4 modules	5509661
	DUAL silencer for FM600 series fan with air grille	5501813
	DUAL silencer for FM6800 series fan with air grille	5501830
	DUAL silencer for FM1000 series fan with air grille	5501854
	DUAL silencer for FM600 series fan with air grille and rain cover	5501814
	DUAL silencer for FM6800 series fan with air grille and rain cover	5501832
	DUAL silencer for FM1000 series fan with air grille and rain cover	5501855
	DUAL silencer for FM600 series fan with flanged outlet for duct connection	5501815
	DUAL silencer for FM6800 series fan with flanged outlet for duct connection	5501833
	DUAL silencer for FM1000 series fan with flanged outlet for duct connection	5501856
	Isolation box for FM pressure tank, 2 modules	5501317

## FMKZ cassette filter, EX

附件		产品编号
	Isolation box for FM pressure tank, 4 modules	5501318
	Isolation box for FM pressure tank, 6 modules	5501319
	Isolation box for FM pressure tank, 6 modules	5501320
	Level sensor with beacon, 230V	5504475
	Cable gland M40 for levelsensor	5512245
	Noise enclosure for FM800 fan	5501783

## FMKZ cassette filter, EX

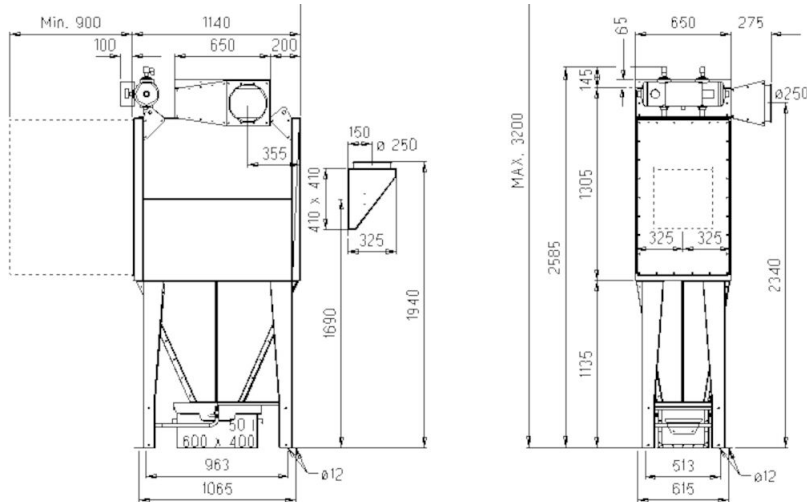

FMK(Z)25-2E Bin

All dimensions in mm.

If 50 liter bin with rollers, add 90 mm.

\* 65 mm to be included at top mounted fan

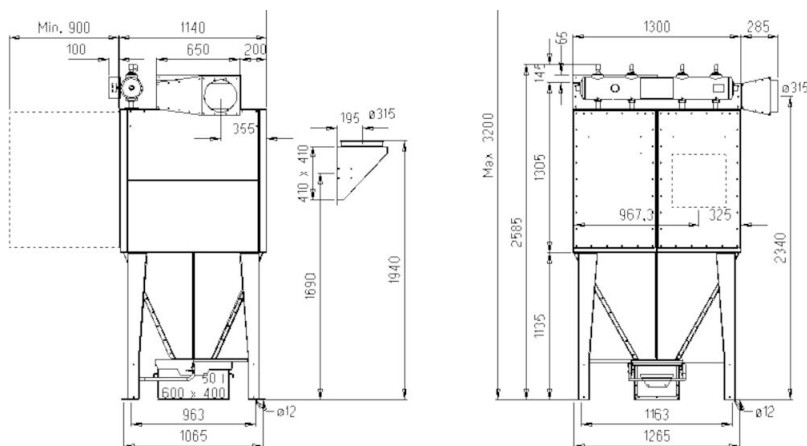

FMK(Z)25-4E Bin

All dimensions in mm.

If 50 liter bin with rollers, add 90 mm.

\* 65 mm to be included at top mounted fan

## FMKZ cassette filter, EX

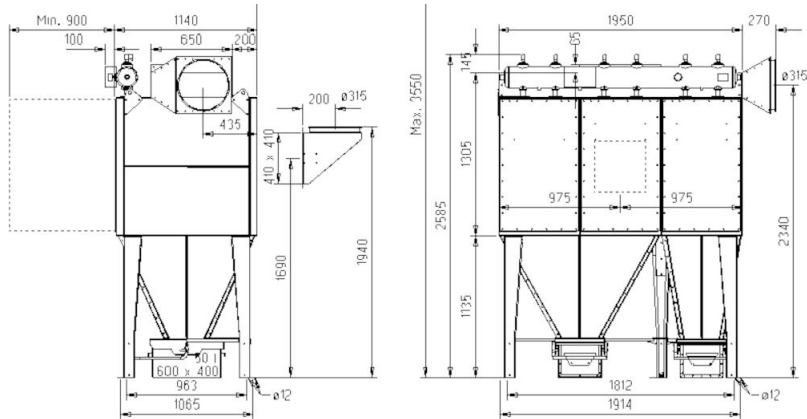

FMK(Z)25-6E Bin

All dimensions in mm.

If 50 liter bin with rollers, add 90 mm.

\* 65 mm to be included at top mounted fan

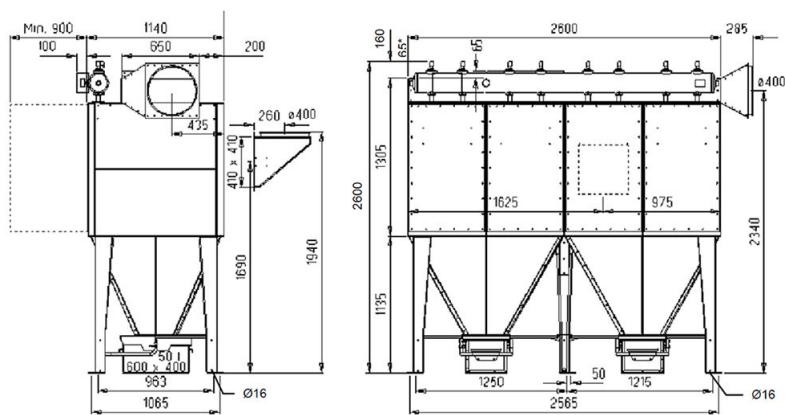

MK(Z)25-8E Bin

All dimensions in mm.

If 50 liter bin with rollers, add 90 mm.

\* 65 mm to be included at top mounted fan

## FMKZ cassette filter, EX

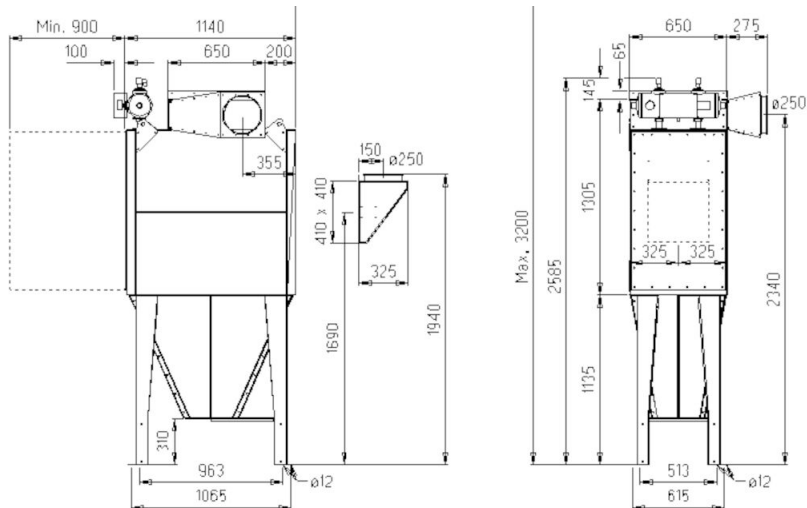

FMK(Z)25-2E Flange

All dimensions in mm.

\* 65 mm to be included at top mounted fan.

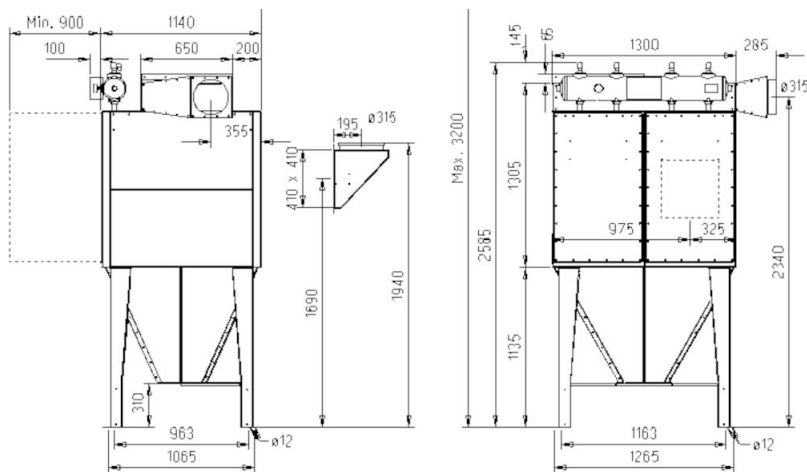

MK(Z)25-4E Flange

All dimensions in mm.

\* 65 mm to be included at top mounted fan.

## FMKZ cassette filter, EX

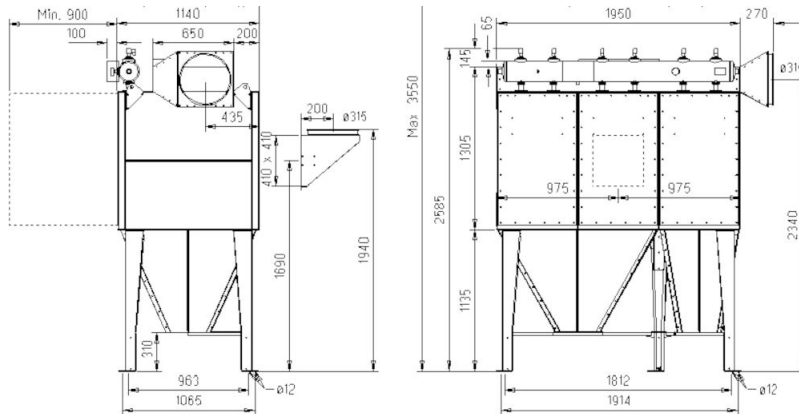

FMK(Z)25-6E Flange

All dimensions in mm.

\* 65 mm to be included at top mounted fan.

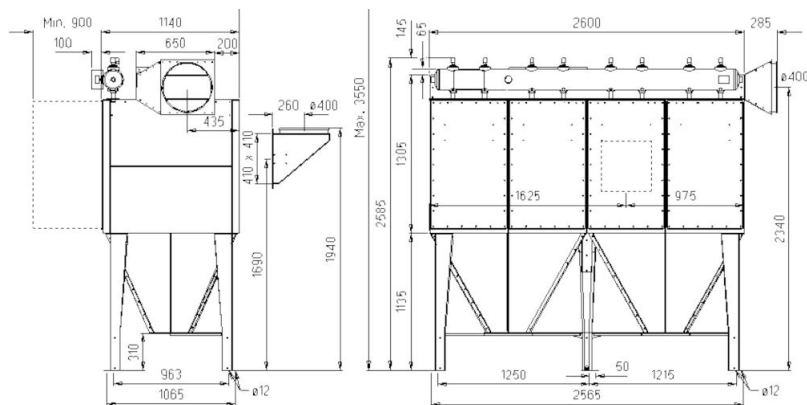

MK(Z)25-8E Flange

All dimensions in mm.

\* 65 mm to be included at top mounted fan.