

MJC cartridge dust collector

Reverse jet tubular bag dust collectors for many applications that generate light to heavy volumes of any dust

MJC cartridge dust collector



Suitable for many different applications that generate light to heavy volumes of any dust

The MJC range of reverse jet tubular bag dust collectors was developed for continuous operation in industrial process filtration and dust collection applications; incorporating patented Nederman UniClean cartridge technology for maximum cleaning efficiency and extended life.

Air Volume Range: 1.700 to 68.000 m³/hr (1,000 to 40,000 CFM)

Cleaning controller type NF8HD250 in IP65 enclosure, supply voltage 230/220/110V.

Key features:

Standard filter range from 48 to 739m² (517 to 7,955 ft²); larger units possible

Typical airflow volumes up to 60.000m³/h (35,340 CFM), or more, subject top application

Robust weatherproof welded steel construction

Space saving integral fans from 0.75 to 18.5kW (1 to 25hp)

Independently tested with ATEX compliant features for St1, St2 and St3 dusts

Integral pre-separation chamber, cross flow / down flow inlet air pattern

Wide range of discharge and waste handling options

Typical dust control and process applications:

Bulk materials handling - conveying, screening, sieving, mixing, bin/silo venting

Shot, sand and bead blasting

Shot, sand and bead blasting

Welding and cutting - laser, plasma, arc

Chemical, plastics and pharmaceutical powders

品名	MJC cartridge dust collector
标准	2014/34/EC, 2004/108/EC, 2006/95/EC, EN 13463-1, EN 60204-1
压缩空气消耗量	-8,0 to 5,5
安装	室内, 室外
材料	Housing: 2,0mm welded painted steel Clean air chamber: 2,0mm thick steel Dirty air chamber 2,0mm or 3,0mm Hopper typically 2,5mm thick.
适用于易爆粉尘	True
清灰方式	脉冲清灰
应用	粉尘, 沙砾, 烟气
工作压力 (千帕)	Standard: -8,0 to 2,0

MJC cartridge dust collector

	Optional: -15,0 to 5,0
灰斗容量	75
过滤面积 (平方米)	48 to 739
性能 (最大风量m ³ /h)	190000
工作温度	-10 to 80 Deg. C.
除尘器类型	滤筒式过滤器
滤芯	Polyester



MJC cartridge dust collector

产品名称	滤芯数量	产品编号
MJC 64/40/44	16	MJC64/40/45*
MJC 80/40/54	20	MJC80/40/55*
MJC 96/40/38	24	MJC96/40/39**
MJC 128/40/48	32	MJC128/40/49**
MJC 160/40/58	40	MJC160/40/59**
MJC 192/40/68	48	MJC192/40/69**
MJC 224/40/78	56	MJC224/40/79**
MJC 256/40/88	64	MJC256/40/89**
MJC 288/40/98	72	MJC288/40/99**
MJC 60/66/33	9	MJC60/66/33*
MJC 79/66/43	12	MJC79/66/43*
MJC 105/66/44	16	MJC105/66/44*
MJC 132/66/54	20	MJC132/66/54*
MJC158/66/38	24	MJC158/66/38**
MJC 211/66/48	32	MJC211/66/48**
MJC 264/66/58	40	MJC264/66/58**
MJC 316/66/68	48	MJC316/66/68**
MJC 369/66/78	56	MJC369/66/78**
MJC 422/66/88	64	MJC422/66/88**
MJC 475/66/98	72	MJC475/66/98**
MJC 528/66/10-8	80	MJC528/66/10-8
MJC 580/66/11-8	88	MJC580/66/11-8***
MJC 634/66/12-8	96	MJC634/66/12-8***
MJC 686/66/13-8	104	MJC686/66/13-8***
MJC 739/66/14-8	112	MJC739/66/14-8***

*Unit has built-in pre-separation chamber at rear

**Unit has built-in pre-separation chamber at side, left or right

***Unit has built-in pre-separation chamber in the centre

MJC cartridge dust collector

Fan size	Fan + silencer	Dimension F
[kW]	[kg]	[mm]
up to 3,0	67	1396
4,0 to 7,5-S	108	1685
7,5-L to 18,5	188	1850

Fan size data

MJC Unit Type 40 cartridges	A1 Clean air chamber (CAC) width	A2 Add for side pre- separation chamber	A Dirty air Chamber (DAC) hopper width	B Depth of clean and dirty air chamber and hopper	C CAC plus DAC plus hopper height	D Dirty air chamber height	E Hopper height 75 litre bin	Typical weights using normal construction kg		No. of bins
								Filter Unit	Hopper	
NOTE: Three units below have built-in pre-separation chamber at rear										
48/40/43	1150	N/A	1150	1220	3395	1050	1467	385	354	1
64/40/44	1500	N/A	1500	1570	3755	1050	1867	622	490	1
80/40/54	1850	N/A	1850	1570	3935	1050	2007	723	558	1
NOTE: Seven units below have built-in pre-separation chamber at side, left or right										
96/40/38	1150	350	1500	2095	4195	1050	2267	770	716	1
128/40/48	1500	700	2200	2095	4365	1050	2437	834	852	1
160/40/58	1850	700	2550	2095	4195	1050	2267	985	957	2
192/40/68	1850	700	2550	2095	4195	1050	2267	1017	957	2
224/40/78	2200	700	2900	2095	4195	1050	2267	1155	1025	2
256/40/88	2550	700	3250	2095	4195	1050	2267	1347	1093	2
288/40/98	2900	700	3600	2095	4195	1050	2267	1512	1161	2

MJC Type 40 (4.0 m cartridge) options

MJC cartridge dust collector

MJC Unit Type 66 cartridges	A1 Clean air chamber (CAC) width	A2 Add for side pre- separation chamber	A Dirty air Chamber (DAC) hopper width	B Depth of clean and dirty air chamber and hopper	C CAC plus DAC plus separation height	D Dirty air chamber height	E Hopper height 75 litre bin	Typical weights using normal construction kg		No. of bins
								Filter Unit	Hopper	
NOTE: Three units below have built-in pre-separation chamber at rear										
60/66/33	1150	0	1150	1220	3765	1420	1467	441	354	1
79/66/43	1150	0	1150	1220	3765	1420	1467	458	354	1
105/66/44	1500	0	1500	1570	4125	1420	1827	721	490	1
132/66/54	1850	0	1850	1570	4305	1420	2007	837	558	1
NOTE: Seven units below have built-in pre-separation chamber at side, left or right										
158/66/38	1150	350	1150	2095	4565	1420	2267	852	716	1
211/66/48	1500	700	2200	2095	4735	1420	2437	936	852	1
264/66/58	1850	700	2550	2095	4565	1420	2267	1102	957	2
316/66/68	1850	700	2550	2095	4565	1420	2267	1142	957	2
369/66/78	2200	700	2900	2095	4565	1420	2267	1299	1025	2
422/66/88	2550	700	3250	2095	4565	1420	2267	1500	1093	2
475/66/98	2900	700	3600	2095	4565	1420	2267	1679	1161	2
NOTE: Five units below have built-in pre-separation chamber in the centre										
528/66/10-8	3550	950	4300	2095	4735	1420	2437	2001	1297	2
580/66/11-8	3700	950	4650	2095	4565	1420	2267	2167	1423	3
634/66/12-8	3700	950	4650	2095	4565	1420	2267	2212	1423	3
686/66/13-8	4050	950	5000	2095	4565	1420	2267	2372	1491	3
739/66/14-8	4400	1300	5700	2095	4735	1420	2437	2532	1560	3

MJC Type 66 (6,6 m cartridge) options

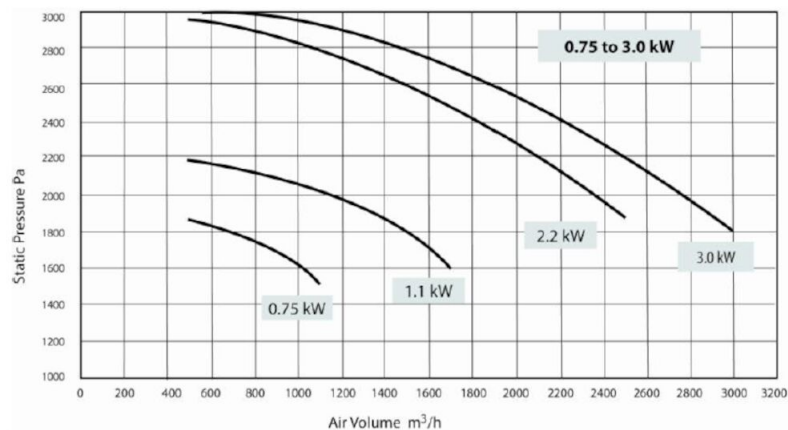

Performance of standard integral fan 0,75 – 3,0 kW, with open outlet, at running speed 2900/min.

MJC cartridge dust collector

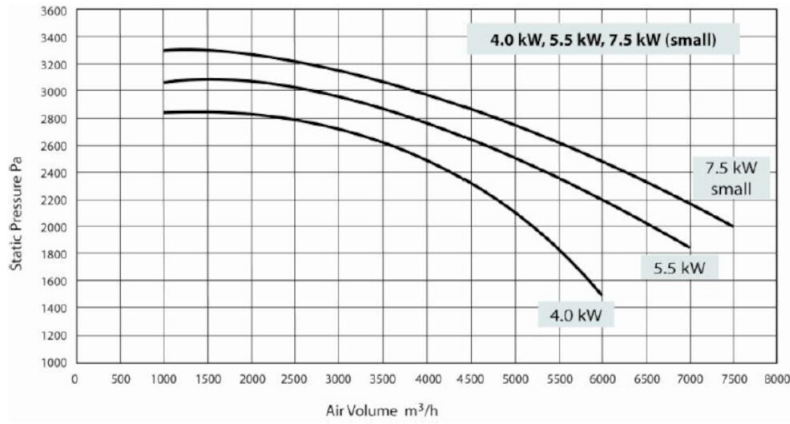

Performance of standard integral fan 4,0 – 7,5 kW, with open outlet, at running speed 2900/min.

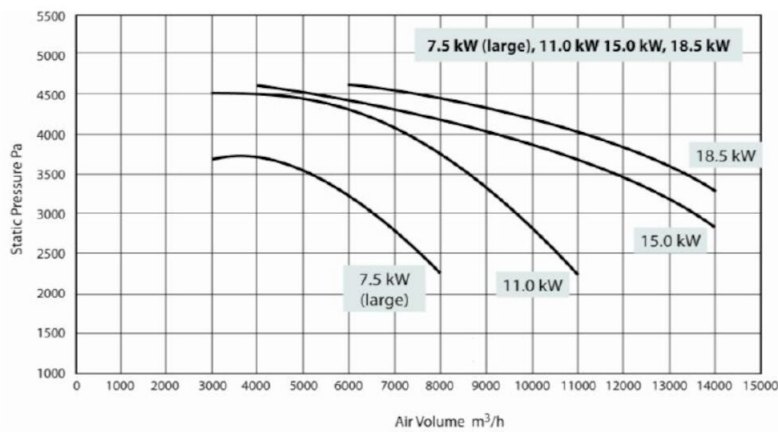

Performance of standard integral fan 7,5 – 18,5 kW, with open outlet, at running speed 2900/min.

MJC cartridge dust collector



Fans

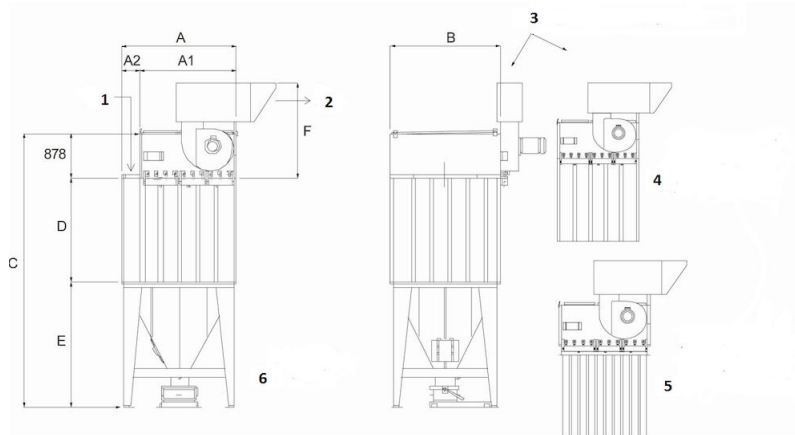

Front and side view of standard MJC complete with typical fan and silencer, mounted on a bin hopper. Rotary valve, flap valve and other discharge options available.

Explanation figures:

- 1) Air inlet
- 2) Air outlet
- 3) Fan and silencer optional
- 4) Open base venting with mounting flange at base of dirty air chamber
- 5) Insertable venting unit with mounting flange at base of clean air chamber
- 6) Hopper outlet flange