

SiloSafe Filter

Compact reverse jet tubular cartridge dust collector



Specifically suited for use on silos that are pneumatically filled. The SiloSafe compact reverse jet tubular cartridge dust collector, available as a venting filter or with an integral fan, was developed specifically for silo and bin venting applications – incorporating Nederman UniClean (patented) cartridge technology for maximum cleaning efficiency and extended life.

Typical applications for the SiloSafe filter are venting of pneumatically and continuously filled silos and bins, for cement batching and in distribution facilities.

- Robust fully welded steel, hot dip galvanized construction. Weatherproof for exposed locations.
- High strength, independently tested to resist explosions, for ATEX compatibility.
- Tough integral mounting flange.
- Low height, minimal visual impact.
- Safe maintenance from clean air side.

Produktnavn	SiloSafe Filter
Installasjon	Innendørs, Utendørs
Materiale	4mm fully-welded steel
Egnet for brennbart støv	True
Rengjøringsmetode, filter	[CompressedAir]
Bruksområde	[grit], Støv, [granulate]
Arbeidstrykk (kPa)	-8 / +2
Filterområdet (m ²)	24
Kapasitet (maks. luftstrøm m ³ /t)	2600
Frekvens Hz	50 / 60
Filtertype	Kassettfilter
Antall filterelementer	6
Filtermateriale	Polyester
Kraft (kW)	2,2



SiloSafe Filter

Spänning (V)	Antall faser	Vekt (kg)	Model
220	1	210	SiloSafe 24
380 / 415	3	245	SiloSafe 24F

SiloSafe Filter

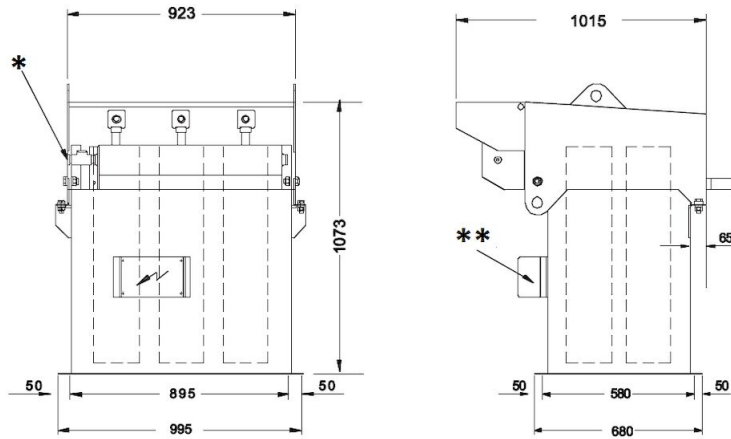

* 3/4" BSP Female connection for Air supply.

** Controller with IP65 enclosure & local isolator requiring 110V or 220 V supply

SiloSafe Filter

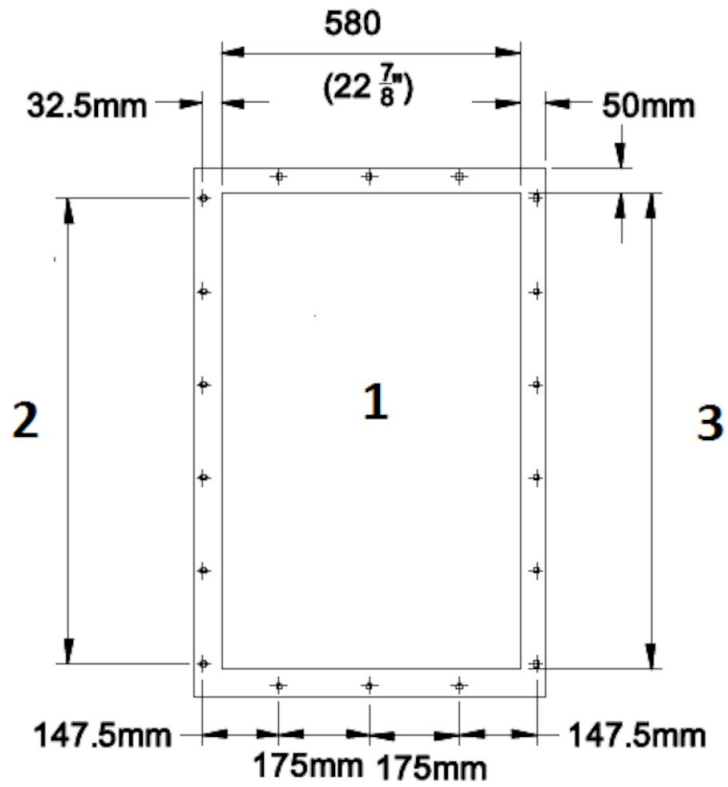

- Filter mating Flange details:
1. 18 Holes 12 dia.
 2. 5 pitches at 175 mm
 3. 1/ Flange

SiloSafe Filter

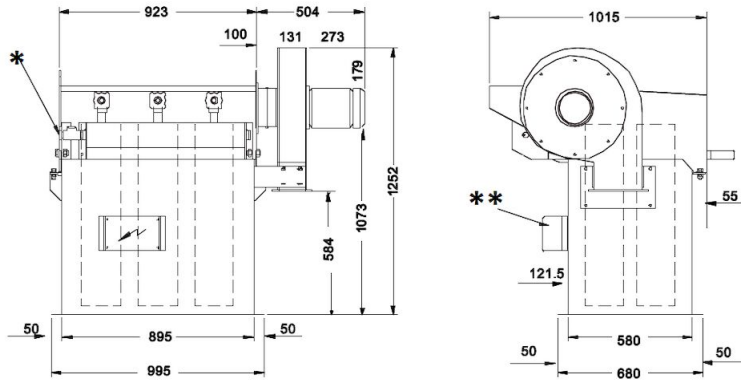

* 3/4" BSP Female connection for Air supply.

** Controller with IP65 enclosure & local isolator requiring 110V or 220 V supply

SiloSafe Filter

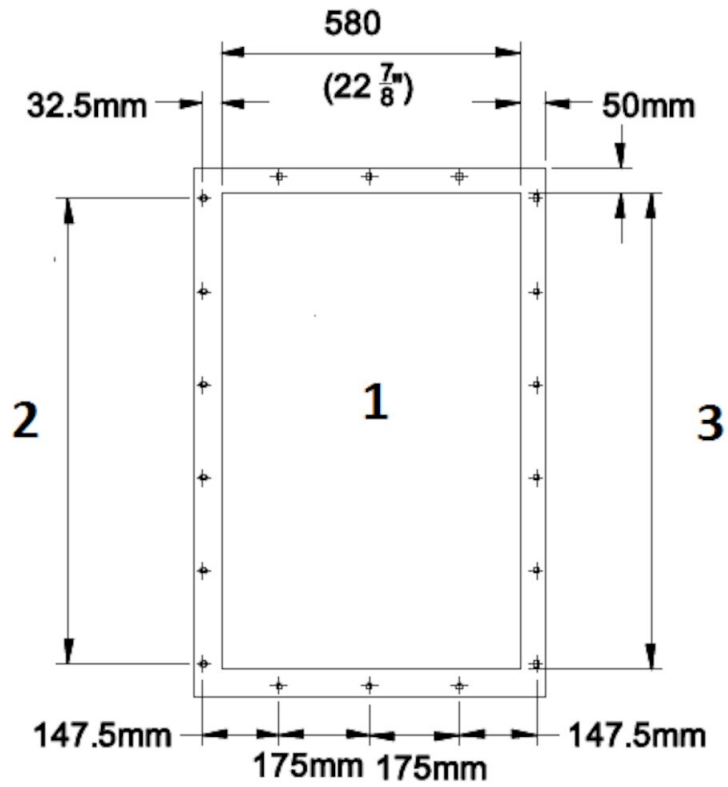

Filter mating Flange details:

1. 18 Holes 12 dia.
2. 5 pitches at 175 mm
3. 1/ Flange