

## 570A, Configurable

A powerful dust collector, excellent high vacuum for suction over long horizontal and vertical distances

---

## 570A, Configurable



The configuration of modules will be similar to 570A which are aimed for the toughest applications, for example handling a lot of abrasive and heavy material. The robustness of the unit and the power from the reliable ejector makes the unit very suitable for many applications where many industrial vacuum cleaners can not be used. For example to collect blasting material in blasting hall, sand recovery in foundries etc.

Your unit can be configured to meet your specific demands. Different ejectors can be used depending on the demand but also the availability of compressed air. The ejector can be placed on a mobile silo with filter, with wheels and forklift slots. Nederman has a range of different discharge valves that can be fitted to the silo for easy discharge of the collected material. If handling larger quantities of material, Nederman recommends using a pre separator before the vacuum unit. See Nederman Engineering Guide for more information.

Use modules linked to 570A, configurable only. You may only choose ejectormodule, filtermodule, silomodule and discharge valve

1. Select ejectormodule depending on required vacuum and air flow.
2. Select filtermodule depending on filter capacity.
3. Select silomodule.
4. Select discharge valve.
5. Select cleaning equipment.

Choose how to control your butterfly valve:

1. Electric controlled - You need a namur valve, solenoid valve recommended for the ejector size you choose and a control box.
2. Air controlled - You need a namur valve.

Hose for air supply to the namur valve is not supplied by Nederman.

Control system with many different functions is available as an accessory

Ensure you meet all requirements for your modules.

- Silo system with large wheels
- Suitable for heavy and or abrasive material
- Robust and efficient self-cleaning filter

Product naam	570A, Configurable
Filter reinigingsmethode	[CompressedAir]
Applicatie	Stof, Granulaten, Grit, Spaanders
Persluchtsbehoefte	4,3 Nm <sup>3</sup> /min @ 7 bar
Max airflow (m <sup>3</sup> /h)	330 Nm <sup>3</sup> /h
Noise level (dB(A))	77
Max. vacuüm	-68
Gewicht (kg)	18
Toelichting van technische gegevens	Recommended with filtermodule 43162101

## 570A, Configurable

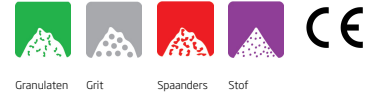



## 570A, Configurable

[image]	Naam voor Datasheet	[model]
	NE64, Ejectormodule with S200 lid and 2 quick couplings	43051000*

*\*Recommended with filtermodule 43162101*

## 570A, Configurable

[accessory]		[partno]
	Pneumatically operated butterfly discharge valve	43630500*
	Zuigslang PU12 Ø 76 mm L=20m	43834300

\*Ø125mm Housing in NBR, Epoxy coated cast iron and flap/sleeve i stainless steel. Temp range -20C to +120C. Height - 110 mm (260 mm in open position)

## 570A, Configurable

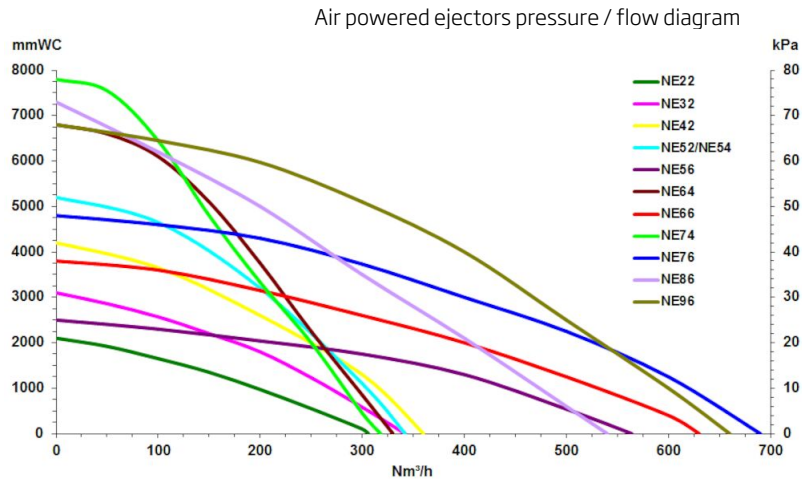

Air Powered ejectors

All performance data are based on 7 bar supply pressure

Ejector/Hose dimension	ø51mm	ø63mm	ø76mm
NE64	2	2,4	N/A
NE74	2,3	2,7	N/A
NE76	1,7	2,7	3,6
NE96	2,6	3,6	4,9

Capacity (tonne/hour) with Blasting media 2,4kg/liter and 20m hose

## 570A, Configurable

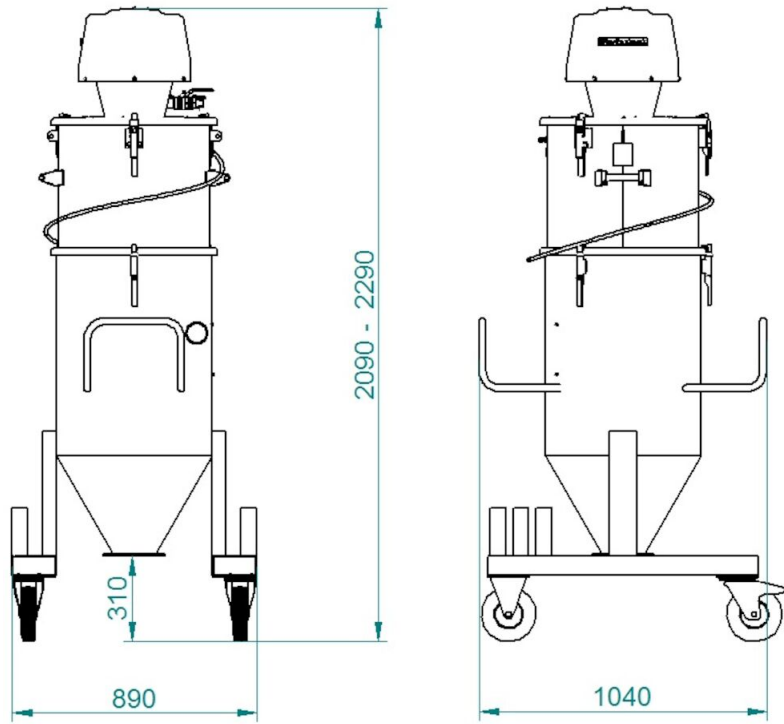

The height of the configuration is depending on filtermodule choosen.