

BenchTop Extraction Arm FX2 100 CHEM

The best and most cost-efficient solution for extraction of hazardous airborne contaminants, in applications where small, flexible and easy-to-use arms are required.











Nederman FX2 arms are made of lightweight anodized aluminium sections, with three adjustable, composite friction joints. Offering strength and durability combined with easy handling, they can be used in many types of environment. They are especially suitable for applications where small, flexible and easy-to-use arms are required. With the profiles made of anodized aluminum with a white electrophoretic deposition coating, the arm is ideal for fume extraction in aggressive environments where corrosion resistance must be assured.

- Optimal efficiency and low noise provides safe and quiet working environment
- Ceilings, walls and floors or fixed to worktops mountings and cut2fit extension profile gives maximum installation flexibility
- The two outermost arm joints can rotate and swivel through 360°, which gives the unique maneuverability
- The lean, smooth and aesthetic design allows arms to fit in well in any environment without compromising its durability and reliability
- Highly integrated products that save customers' time and costs, as well as providing the reliability and functionality to deliver a better performance

Product name	BenchTop Extraction Arm FX2 100 CHEM
Noise level (dB(A))	62 dB(A) at 450 m ³ /h
Installation	[Indoor]
Material	Tubes in anodized aluminium with a white electrophoretic deposition coating. Joints in PP plastic. Duct connector in EPDM rubber. Minihood in PP plastic.
Fume temperature	max 70°C
Extraction arm diameter (mm)	100
Airflow (m ³ /h)	200 - 450
Colour	White



BenchTop Extraction Arm FX2 100 CHEM

Image	Description	Arm length (m)	Weight (kg)	Model
	FX2-CHEM-D100-L1200-Up/Down-Low	1,2	4,8	70605644*
	FX2-CHEM-D100-L1200-Up-PLUS	1,2	5,9	70605744**
	FX2-CHEM-D100-L1200-Up/Down-Through	1,2	4,1	70605844***
	FX2-CHEM-D100-L1800-Up-Low	1,8	5,9	70605944****
	FX2-CHEM-D100-L1800-Up-PLUS	1,8	7,7	70606044**
	FX2-CHEM-D100-L1800-Down-Low	1,8	5,9	70606144*****
	FX2-CHEM-D100-L1800-Down-Through	1,8	5,9	70606244*****
	FX2-CHEM-D100-L2400-Up-Low	2,4	6,9	70606344****
	FX2-CHEM-D100-L2400-Up-PLUS	2,4	8,7	70606444**

*Up/Down-Low

**Up-PLUS











***Up/Down-Through

****Up-Low

*****Down-Low

*****Down-Through

BenchTop Extraction Arm FX2 100 CHEM

	Accessory	Part No
	FX2-Duct connector-ORIG/CHEM-D100	70377040
	FX-Bracket kit-D50/75/100-L190	70501144
	FFX2-Bracket kit-D50/75/100-L500	70377042
	FX2-Wall BRKT kit-Flat-L190-White	70377043
	FX2-Wall-P BRKT kit-D50/75/100-L190	70377046
	FX2-Bench bracket kit-D50/75/100	70501444
	FX-Classic bracket-D50/75/100	70501244
	FX-Cut2fit extension-L1100.	70501344
	FX-Cut2fit extension-L2200	70374600
	FX-Ceiling cover plate	70502644
	FX2-Ceiling cover plate-PLUS	70377045
	FX-Combi hood-CHEM-D50/75/100	70500344
	FX-Dome hood-CHEM-D50/75/100	70376984
	FX-Metal hood-ORIG/CHEM-D50/75/100	70500444
	FX-Flange hood-CHEM-D50/75/100	70503044
	FX2-Al duct-L1000-D75/100toD100-WHT.	70377054
	FX2-Al duct-L2000-D75/100toD100-WHT	70377055
	FX-Hose-D100-L3000-Grey	70377099
	FX-Hose D125-L5000-Grey	70377100
	FX2-Hose support ring-D100	70377068
	FX2-Hose support ring-D125	70377069

BenchTop Extraction Arm FX2 100 CHEM

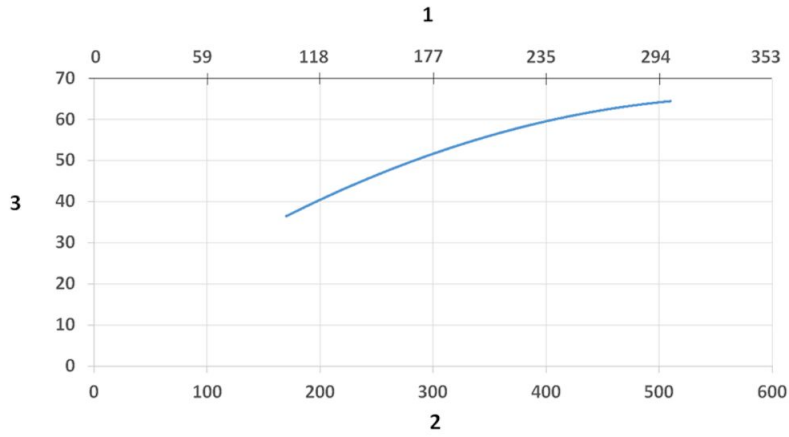

Sound Level diagram:

1) X- Axis: Air Flow Rate (cfm)

2) X- Axis: Air Flow Rate (m/h)

3) Y-Axis: Sound Pressure Level (dB) (A)

BenchTop Extraction Arm FX2 100 CHEM

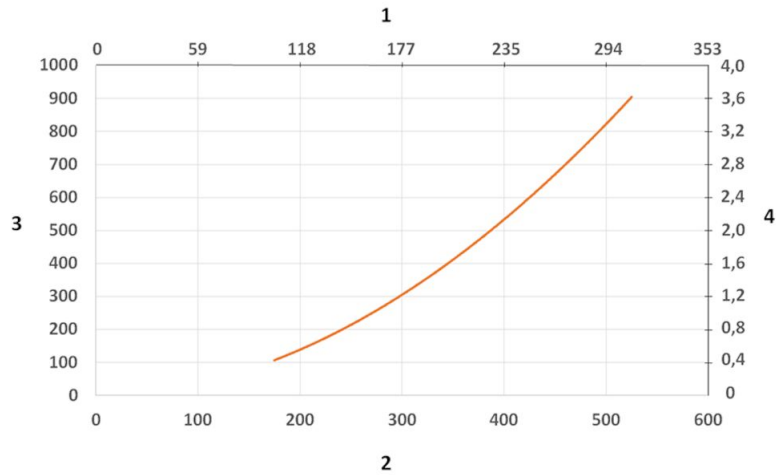

Pressure Drop diagram:

- 1) X- Axis: Air Flow Rate (cfm)
- 2) X- Axis: Air Flow Rate (m/h)

- 3) Y- Axis: Static Pressure Drop (Pa)
- 4) Y- Axis: Static Pressure Drop (in. wg.)

BenchTop Extraction Arm FX2 100 CHEM

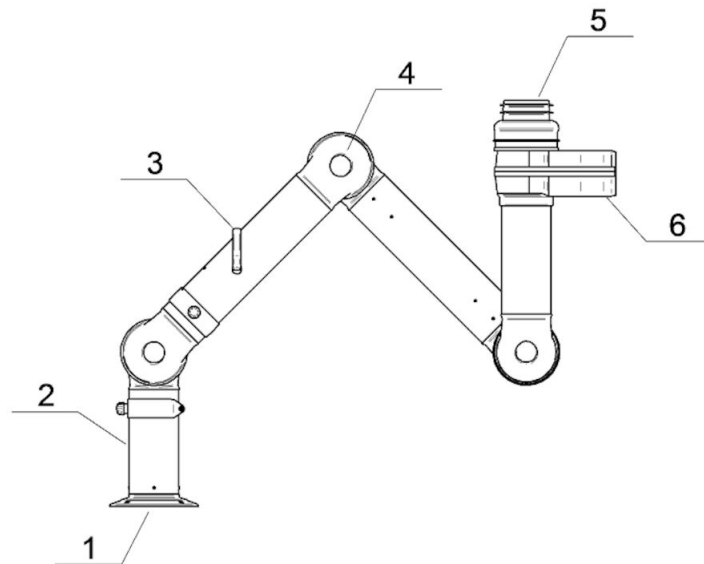

Material:

1) Flange: PP

2) Tubes: Aluminum: anodized 10 µm, with white electrophoretic deposition coating

3) Damper adjustment handle: Aluminum: anodized 10 µm
Internal spring: Stainless steel
Damper blade: Conductive TP & PP plastic

4) Joints: PP with glass fibre reinforcement
Plastic rings: PP with glass fibre reinforcement
Axial locking rings: PP with glass fibre reinforcement
Adjustment knobs: PA & EDS plastic
Threaded shaft inside joints: Stainless Steel

5) Duct connector: EPDM Rubber

6) Swivel: Aluminum, powder coating
Rivets: Aluminum
Bearings swivel: PP with glass fibre reinforcement

BenchTop Extraction Arm FX2 100 CHEM

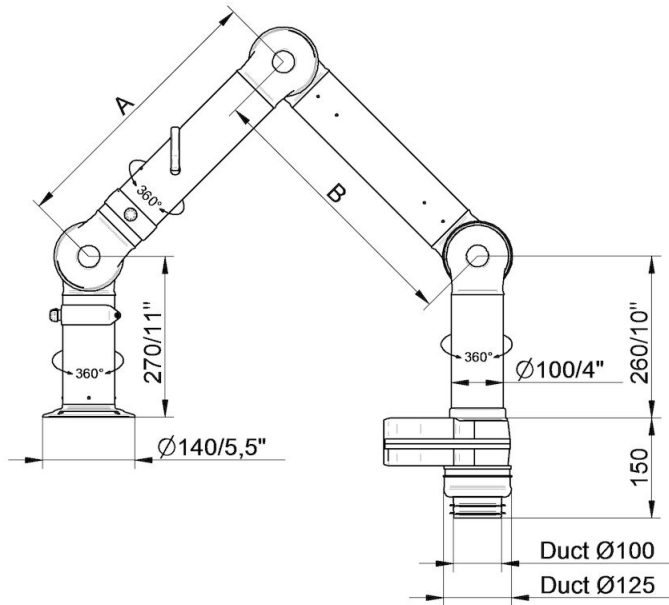

- FX2-CHEM-D100-L1200-Up/Down-Low
Part number: 70605644
Max. working radius: 1170 mm (46,1 in)
A: 450 mm (17,7 in)
B: 450 mm (17,7 in)

- FX2-CHEM-D100-L1800-Down-Low
Part number: 70606144
Max. working radius: 1770 mm (69,7 in)
A: 750 mm (29,5 in)
B: 750 mm (29,5 in)

BenchTop Extraction Arm FX2 100 CHEM

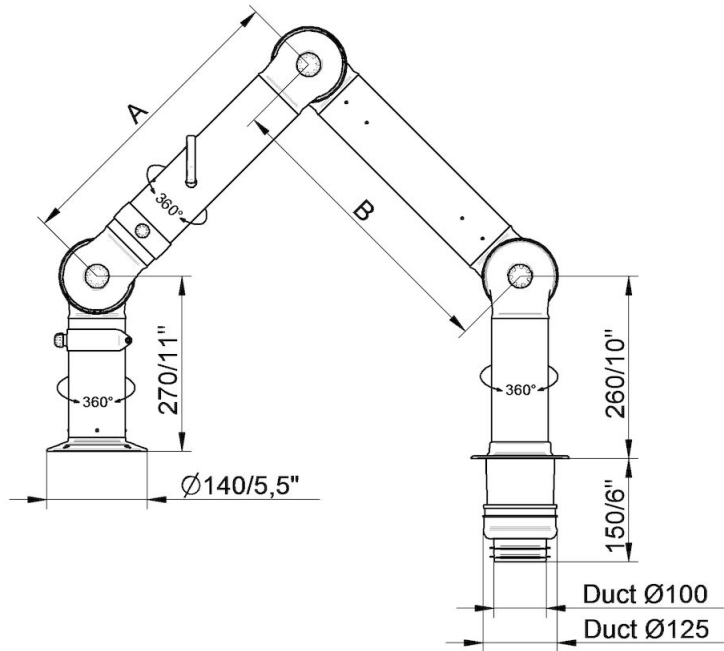

- FX2-CHEM-D100-L1200-Up/Down-Through
Part number: 70605844
Max. working radius: 1170 mm (46,1 in)
A: 450 mm (17,7 in)
B: 450 mm (17,7 in)

- FX2-CHEM-D100-L1800-Down-Through
Part number: 70606244
Max. working radius: 1770 mm (69,7 in)
A: 750 mm (29,5 in)
B: 750 mm (29,5 in)

BenchTop Extraction Arm FX2 100 CHEM

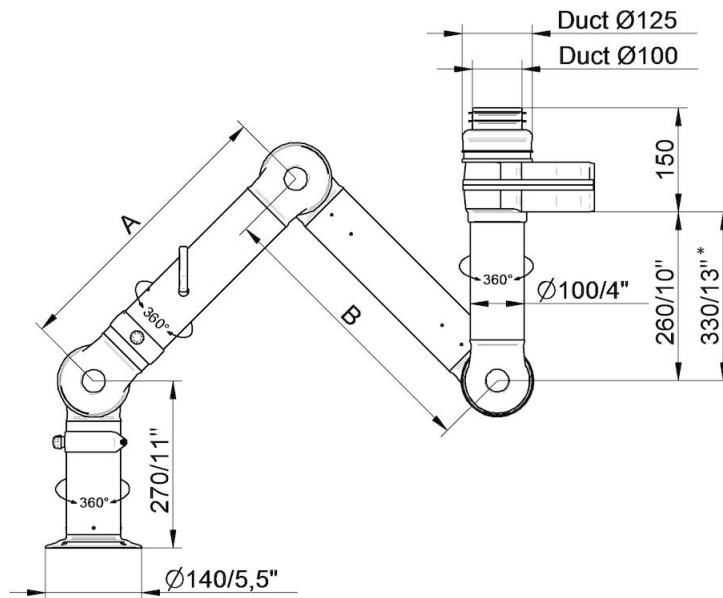

- FX2-CHEM-D100-L1200-Up/Down-Low
Part number: 70605644
Max. working radius: 1170 mm (46,1 in)
A: 450 mm (17,7 in)
B: 450 mm (17,7 in)

- FX2-CHEM-D100-L1800-Up-Low
Part number: 70605944
Max. working radius: 1770 mm (69,7 in)
A: 750 mm (29,5 in)
B: 750 mm (29,5 in)

- * • FX2-CHEM-D100-L2400-Up-Low
Part number: 70606344
Max. working radius: 2290 mm (90,2 in)
A: 1010 mm (39,7 in)
B: 1010 mm (39,7 in)

BenchTop Extraction Arm FX2 100 CHEM

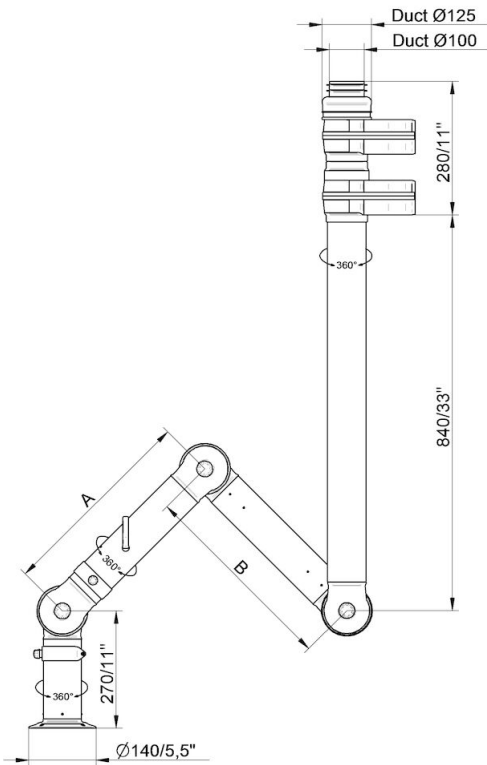

- FX2-CHEM-D100-L1200-Up-PLUS
Part number: 70605744
Max. working radius: 1170 mm (46,1 in)
A: 450 mm (17,7 in)
B: 450 mm (17,7 in)

- FX2-CHEM-D100-L1800-Up-PLUS
Part number: 70606044
Max. working radius: 1770 mm (69,7 in)
A: 750 mm (29,5 in)
B: 750 mm (29,5 in)

- FX2-CHEM-D100-L2400-Up-PLUS
Part number: 70606444
Max. working radius: 2290 mm (90,2 in)
A: 1010 mm (39,7 in)
B: 1010 mm (39,7 in)

BenchTop Extraction Arm FX2 100 CHEM

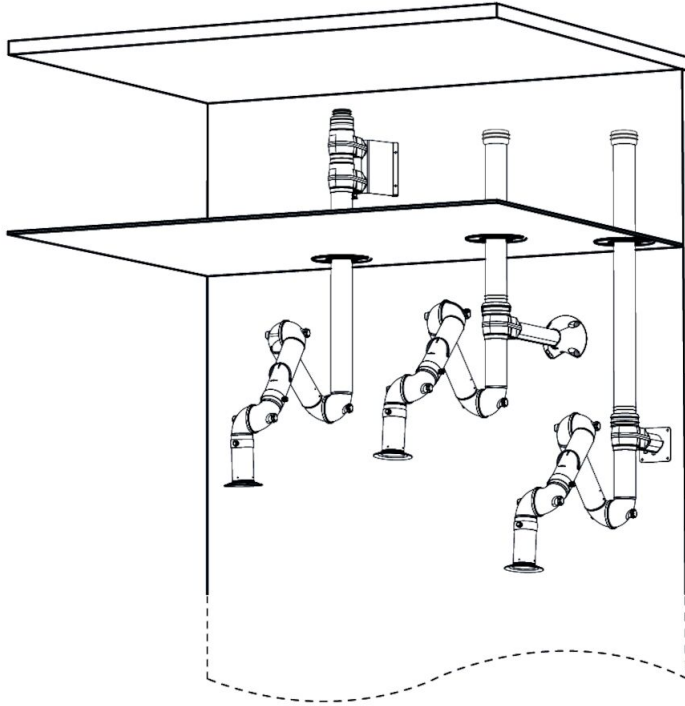

Wall mounting examples:

Left: FX2-Up-PLUS arm with following accessories:

- FX2-Wall-P BRKT kit-D-50/75/100-L190
- FX2-Ceiling cover plate-PLUS

Middle: FX2-Up-Low arm with following accessories:

- FX2-Bracket kit-D-50/75/100-L500
- FX2-Ceiling cover plate-PLUS
- FX2-Alu duct-WHT
- FX2-Duct connector-ORIG/CHEM-D100

Right: FX2-Up-Low arm with following accessories:

- FX2-Wall BRKT kit-Flat-L190-White
- FX2-Ceiling cover plate-PLUS
- FX2-Alu duct-WHT
- FX2-Duct connector-ORIG/CHEM-D100

BenchTop Extraction Arm FX2 100 CHEM

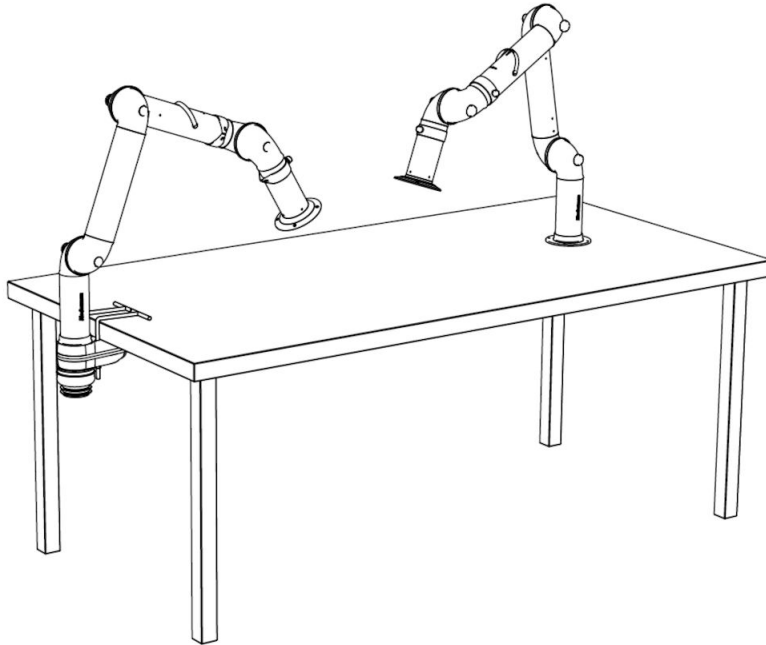

Bench mounting examples:

Left: FX2-Down-Low arm with following accessories:

-FX2-Bench bracket kit-D-50/75/100

Right: FX2-Down-Through arm

BenchTop Extraction Arm FX2 100 CHEM

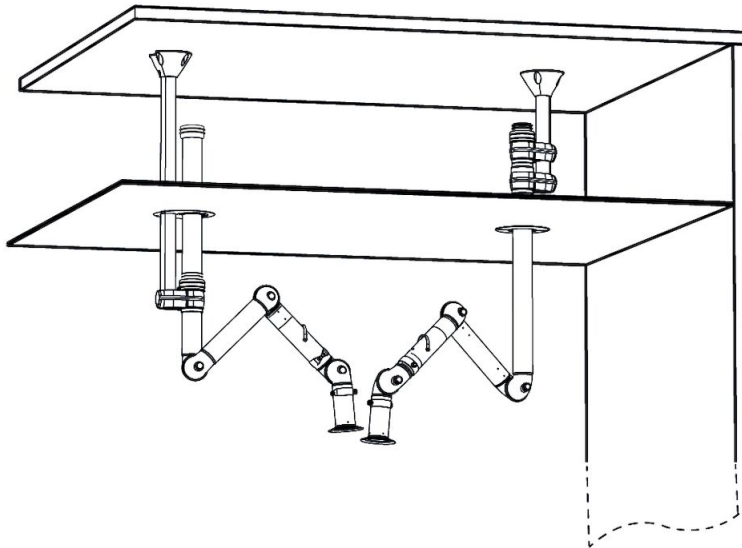

Ceiling mounting example:

Left: FX2-Up-Low arm with following accessories:

- FX-Classic bracket
- FX-Cut2fit extension-L1100
- FX2-Alu duct-WHT
- FX2-Duct connector-ORIG/CHEM-D100
- FX-Ceiling cover plate

Right: FX2-Up-PLUS arm with following accessories:

- FX2-Bracket kit-D-50/75/100-L500
- FX2-Ceiling cover plate-PLUS

BenchTop Extraction Arm FX2 100 CHEM

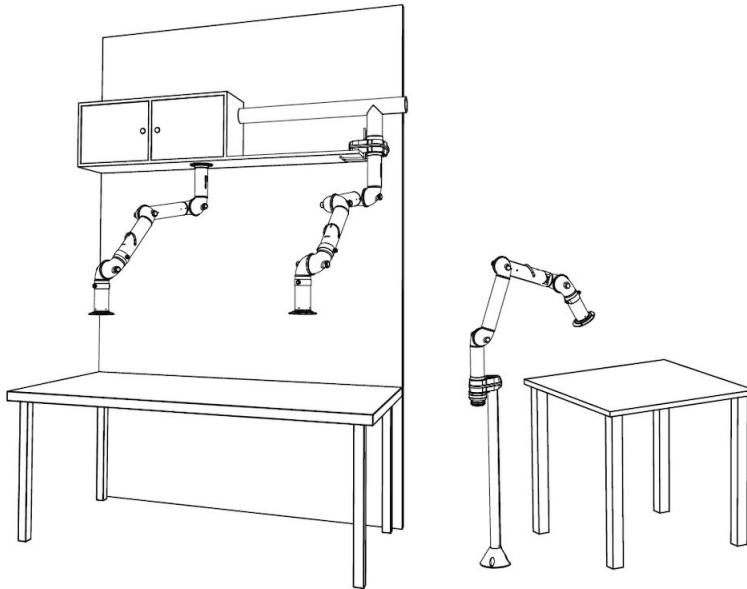

Other mounting examples:

Left: Overbench cabinet mounting with FX2-Up/Down-Through arm

Middle: Shelf mounting with FX2-Up-Low arm and following accessories:

-FX2-Bench bracket kit

Right: Floor mounting with FX2-Up-Low arm and following accessories:

-FX-Classic bracket

-FX-Cut2fit extension-L1100