

BenchTop Extraction Arm FX2 75 ESD/EX

The best and most cost-efficient solution for extraction of hazardous airborne contaminants, in applications where small, flexible and easy-to-use arms are required.



Nederman FX2 arms are made of lightweight anodized aluminium sections, with two or three adjustable, composite friction joints. Offering strength and durability combined with easy handling, they can be used in many types of environment. They are especially suitable for applications where small, flexible and easy-to-use arms are required.





The arm is designed for use in electronic environments where there is a risk of electrostatic discharges. The ESD/EX can also be used for certain applications in potentially explosive atmospheres. Recommended for use in zone 1, 2 and 21, 22.

- Optimal efficiency and low noise provides safe and quiet working environment
- Ceilings, walls and floors or fixed to worktops mountings and cut2fit extension profile gives maximum installation flexibility
- The two outermost arm joints can rotate and swivel through 360°, which gives the unique maneuverability
- The lean, smooth and aesthetic design allows arms to fit in well in any environment without compromising its durability and reliability
- Highly integrated products that save customers' time and costs, as well as providing the reliability and functionality to deliver a better performance





















Product name	BenchTop Extraction Arm FX2 75 ESD/EX
Noise level (dB(A))	58 dB(A) at 240 m3/h
Installation	[Indoor]
Material	Tubes in anodized aluminium. Joints in conductive PP plastic. Duct connector in conductive EPDM rubber. Minihood in conductive PP plastic.
Fume temperature	max 70°C
Extraction arm diameter (mm)	75
Airflow (m³/h)	110 - 240
Arm length (m)	



BenchTop Extraction Arm FX2 75 ESD/EX

[Image]	Description	Weight (kg)	[model]
	FX2-ESD/EX-D75-L1100-Up-Low	3,2	70603944
	FX2-ESD/EX-D75-L1100-Down-Low	3,2	70604144
	FX2-ESD/EX-D75-L1100-Down-Through	2,6	70604244
	FX2-ESD/EX-D75-L1500-Up-Low	3,4	70604344
	FX2-ESD/EX-D75-L1500-Down-Low	3,4	70604544
	FX2-ESD/EX-D75-L1500-Down-Through	2,8	70604644

BenchTop Extraction Arm FX2 75 ESD/EX

	[accessory]	[partno]
	FX-Bracket kit-D50/75/100-L190	70501144
	FX2-Bracket kit-D50/75/100-L500	70377042
	FX2-Wall BRKT kit-Flat-L190-Black. Complete mounting kit, with flat wall bracke,190 mm (7.48 inch) extension profile and associated parts, for mounting FX2 50/75/100 arms with 250 mm (9.84 inch) from the vertical centre line of the arm to the wall.	70377044
	FX2-Bench bracket kit-D50/75/100, Complete mounting kit for mounting FX2 50/75/100 arms on the bench edge.	70501444
	FX-Classic bracket-D50/75/100. The classic bracket should be used together with Cut2fit extension profile for mounting FX2 50/75/100 arms on the ceiling, wall, floor or on top of other horizontal surface.	70501244
	FX-Cut2fit extension-L1100.	70501344
	FX-Cut2fit extension-L2200	70374600
	FX-Ceiling cover plate. Cover false/dropped ceiling openings caused by both extension profile and ducting.	70502644
	FX2-Ceiling cover plate-PLUS	70377045
	FX-Combi hood-ESD/EX-D50/75/100. Black combi hood, made of conductive ABS plastic, is designed to capture low energy contaminants which is explosive or has a risk of electrostatic discharges. It can be attached directly on minihood, irrespective of arm size.The ergonomics of handle design on both sides of the hood make it easier to maneuver.	70500244
	FX-Dome hood-ESD/EX-D50/75/100. Black dome hood, made of conductive ABS plastic,is designed to capture high dispersion contaminants, which is explosive or has a risk of electrostatic discharges. It can be attached directly on minihood, irrespective of arm size. The ergonomics of handle design on both sides of the hood make it easier to maneuver.	70376983
	FX-Metal hood-ESD/EX-D50/75/100	70500544
	FX-Flange hood-ESD/EX-D50/75/100. Black flange hood, made of conductive ABS plastic, is designed to maximize the capture zone without hinder objects on the bench or the user. It can be attached directly on minihood, irrespective of arm size.	70502944
	FX2-Duct connector-ESD/EX-D75	70377039
	FX2-AI duct-L1000-D75/100toD100. Aluminum duct with 100 mm (4 inch) diameter and 1000 mm (39.37 inch) length is designed to replace vertical ventilation duct above the swivel of FX2 75/100 arm. This is a good looking alternative to standard, ventilation duct.	70377058
	FX2-AI duct-L2000-D75/100toD100. Aluminum duct with 100 mm (4 inch) diameter and 2000 mm (78.74 inch) length is designed to replace vertical ventilation duct above the swivel of FX2 75/100 arm. This is a good looking alternative to standard, ventilation duct.	70377059
	FX-Hose-ESD-D75-L3000-Black- Flexible hose in black conductive PE with 75 mm (3 inch) diameter and 3000 mm (118.11 inch) length. It shall be used with hose support ring to connect hose to arm.	70377101
	FX-Hose-ESD-D100-L3000-Black- Flexible hose in black conductive PE with 100 mm (4 inch) diameter and 3000 mm (118.11 inch) length. It shall be used with hose support ring to connect hose to arm.	70377102
	FX2-Hose support ring-D75	70377067
	FX2-Hose support ring-D100. Place into the 100 mm (4 inch) hose to support the connection between the hose and the duct connector of the arm. A must to connect the hose to arm.	70377068

BenchTop Extraction Arm FX2 75 ESD/EX

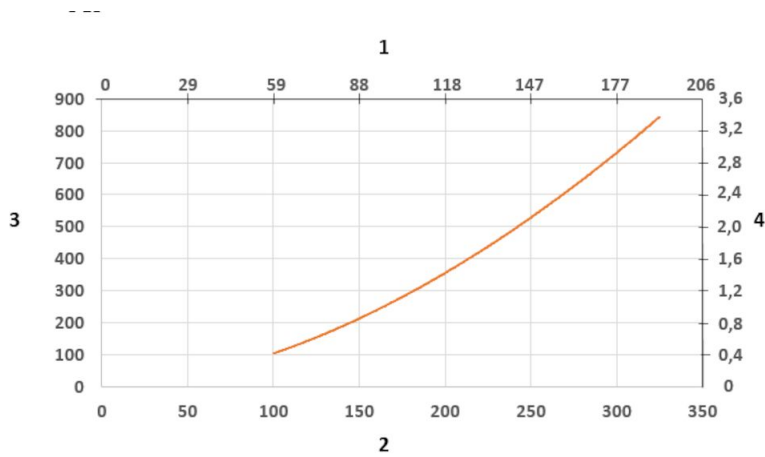

Pressure Drop diagram:

1) X- Axis: Air Flow Rate (cfm)

2) X- Axis: Air Flow Rate (m/h)

3) Y-Axis: Static Pressure Drop (Pa)

4) Y-Axis: Static Pressure Drop (in. wg.)

BenchTop Extraction Arm FX2 75 ESD/EX

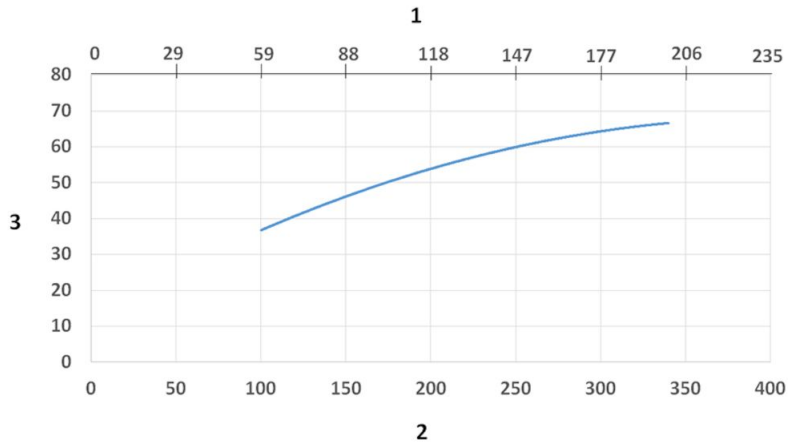

Sound Level diagram:

1) X- Axis: Air Flow Rate (cfm)

2) X- Axis: Air Flow Rate (m/h)

3) Y-Axis: Sound Pressure Level (dB (A))

BenchTop Extraction Arm FX2 75 ESD/EX

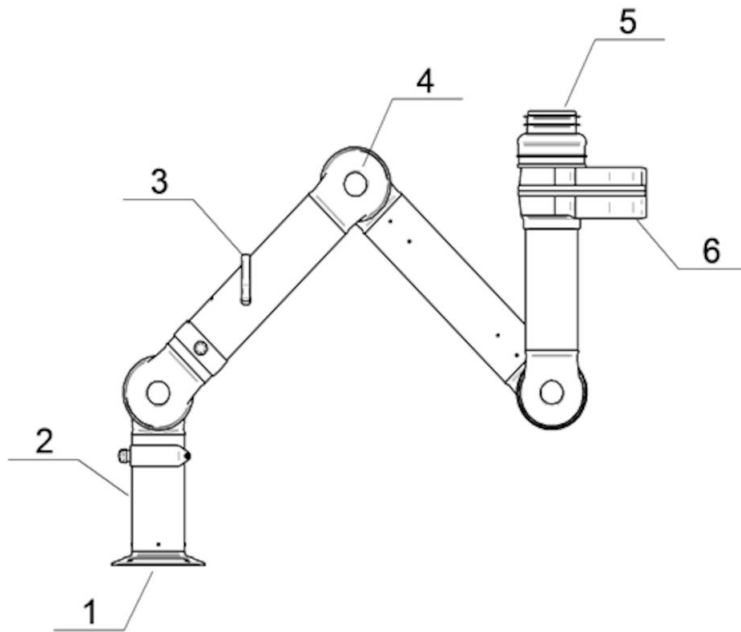

Material:

- 1) Flange: Conductive PP plastic
- 2) Tubes: Aluminum, anodized 10 µm
- 3) Damper adjustment handle: Aluminum: anodized 10 µm
Internal spring: Stainless steel
Damper blade: Conductive TP & PP plastic
- 4) Joints conductive: PP plastic with glass fibre reinforcement
Plastic rings conductive: PP plastic with glass fibre reinforcement
Axial locking rings conductive: PP plastic with glass fibre reinforcement
Adjustment knobs: PA & EDS plastic
Threaded shaft inside joints: Stainless Steel
- 5) Duct connector: conductive EPDM Rubber
- 6) Swivel: Aluminum, conductive powder coating
Rivets: Aluminum
Bearings swivel conductive: PP plastic with glass fibre reinforcement

BenchTop Extraction Arm FX2 75 ESD/EX

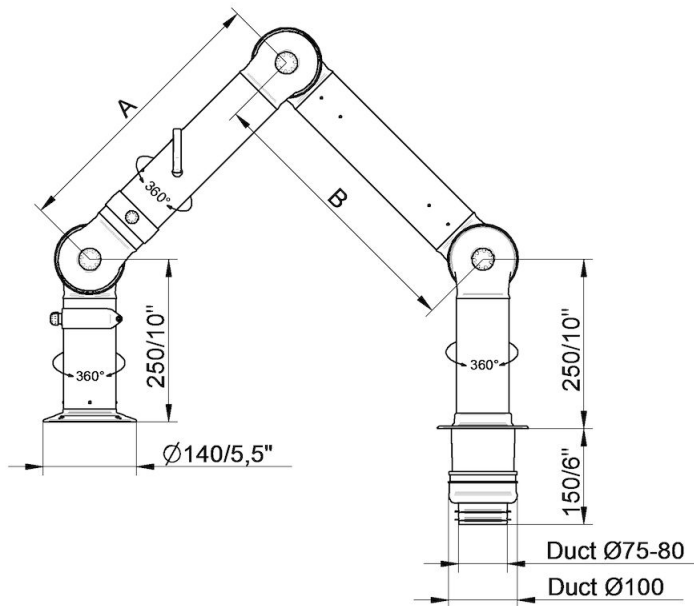

- FX2-ESD/EX-D75-L1100-Down-Through
Part number: 70604244
Max. working radius: 1090 mm (42,9 in)
A: 420 mm (16,5 in)
B: 420 mm (16,5 in)

- FX2-ESD/EX-D75-L1500-Down-Through
Part number: 70604644
Max. working radius: 1450 mm (57,1 in)
A: 500 mm (19,7 in)
B: 700 mm (27,5 in)

BenchTop Extraction Arm FX2 75 ESD/EX

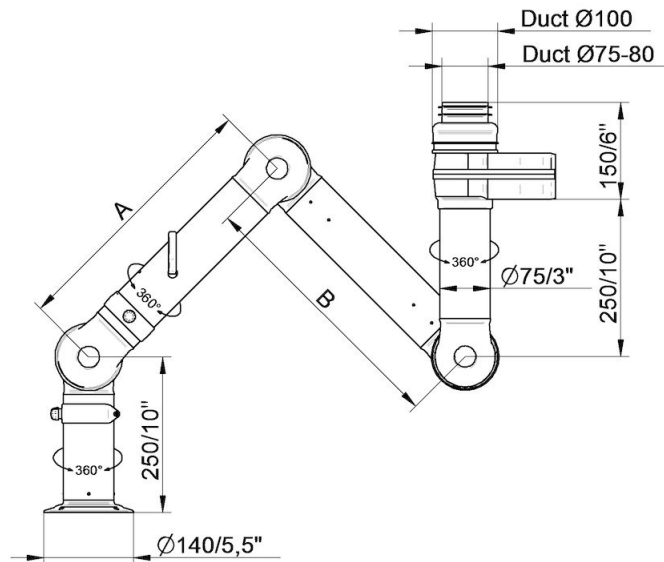

- FX2-ESD/EX-D75-L1100-Up-Low
Part number: 70603944
Max. working radius: 1090 mm (42,9 in)
A: 420 mm (16,5 in)
B: 420 mm (16,5 in)

- FX2-ESD/EX-D75-L1500-Up-Low
Part number: 70604344
Max. working radius: 1450 mm (57,1 in)
A: 500 mm (19,7 in)
B: 700 mm (27,5 in)

BenchTop Extraction Arm FX2 75 ESD/EX

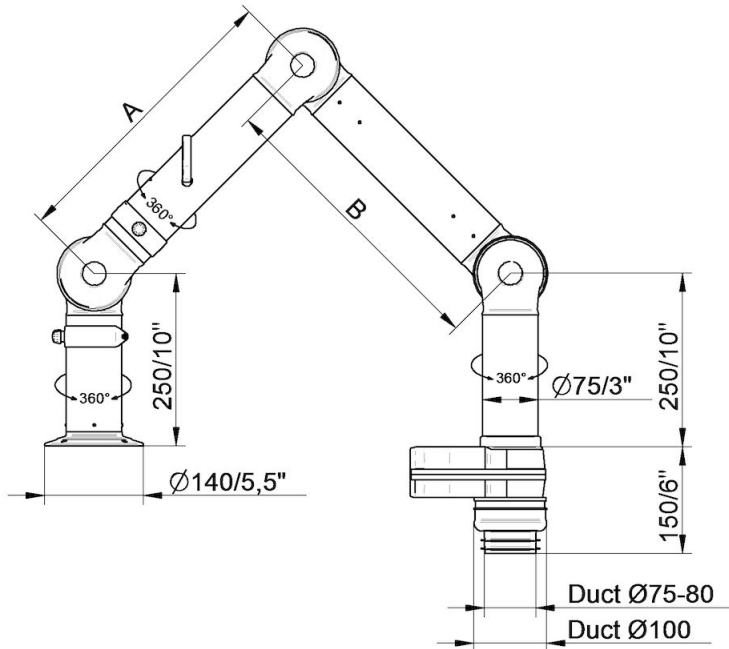

- FX2-ESD/EX-D75-L1100-Down-Low
Part number: 70604144
Max. working radius: 1090 mm (42,9 in)
A: 420 mm (16,5 in)
B: 420 mm (16,5 in)

- FX2-ESD/EX-D75-L1500-Down-Low
Part number: 70604544
Max. working radius: 1450 mm (57,1 in)
A: 500 mm (19,7 in)
B: 700 mm (27,5 in)

BenchTop Extraction Arm FX2 75 ESD/EX

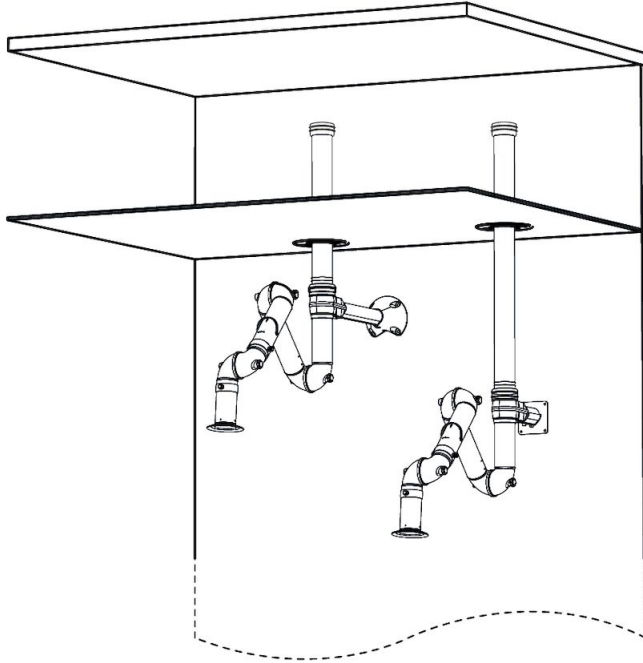

Wall mounting examples:

Left: FX2-Up-Low arm with following accessories:

- FX2-Bracket kit-D50/75/100-L500
- FX2-Ceiling cover plate-PLUS
- FX2-Alu duct
- FX2-Duct connector-ESD/EX-D100

Right: FX2-Up-Low arm with following accessories:

- FX2-Wall BRKT kit-Flat-L190-Black
- FX2-Ceiling cover plate-PLUS
- FX2-Alu duct
- FX2-Duct connector-ESD/EX-D100

BenchTop Extraction Arm FX2 75 ESD/EX

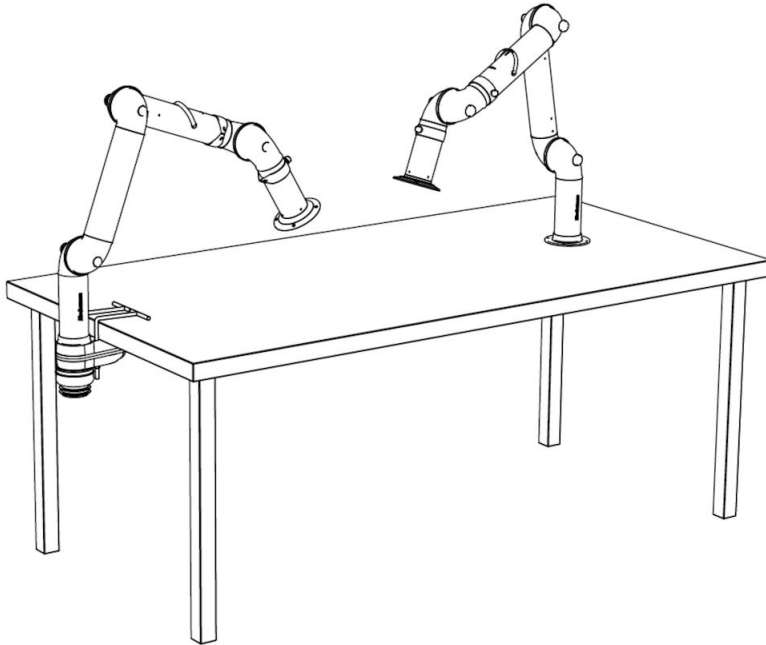

Bench mounting examples:

Left: FX2-Down-Low arm with following accessories:

-FX2-Bench bracket kit-D50/75/100

Right: FX2-Down-Through arm

BenchTop Extraction Arm FX2 75 ESD/EX

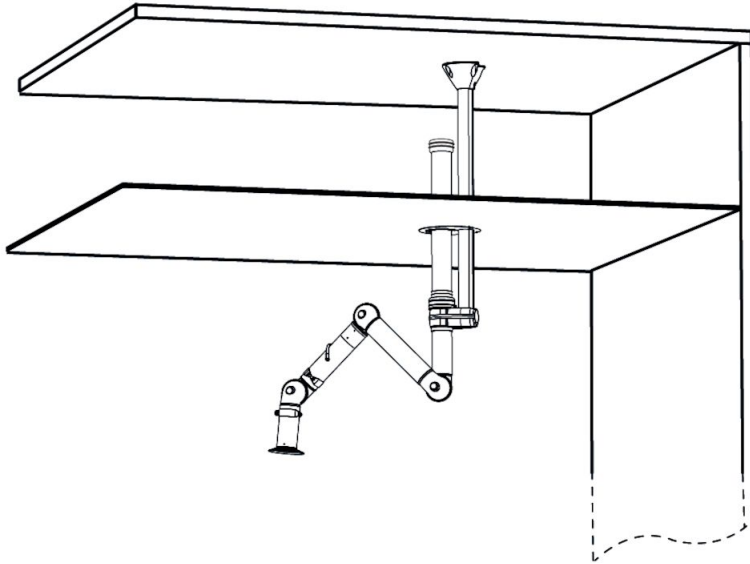

- Ceiling mounting example:
FX2-Up-Low arm with following accessories:
- FX-Classic bracket
 - FX-Cut2fit extension-L1100
 - FX2-Alu duct
 - FX2-Duct connector-ESD/EX-D100
 - FX-Ceiling cover plate

BenchTop Extraction Arm FX2 75 ESD/EX

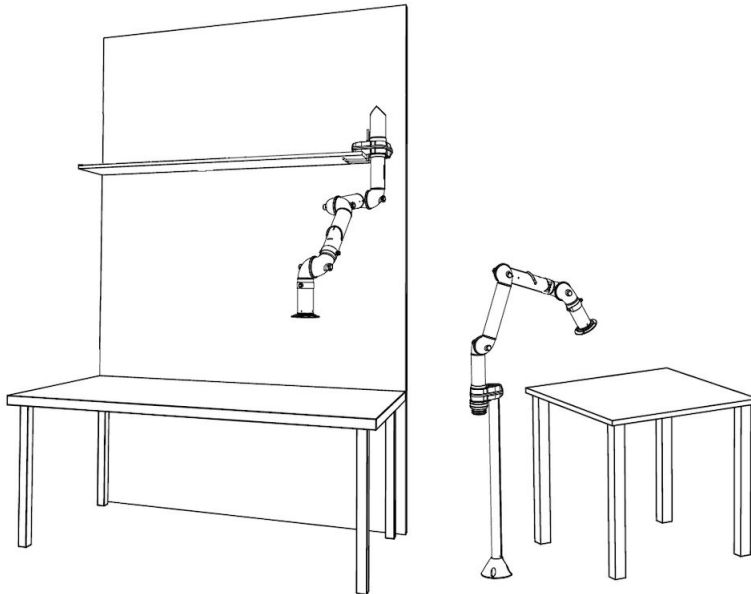

Other mounting examples:

Left: Shelf mounting with FX2-Up-Low arm and following accessories:

-FX2-Bench bracket kit

Right: Floor mounting with FX2-Up-Low arm and following accessories:

-FX-Classic bracket

-FX-Cut2fit extension-L1100