

## BenchTop Extraction Arm FX2 75 ESD/EX

The best and most cost-efficient solution for extraction of hazardous airborne contaminants, in applications where small, flexible and easy-to-use arms are required.



Nederman FX2 arms are made of lightweight anodized aluminium sections, with two or three adjustable, composite friction joints. Offering strength and durability combined with easy handling, they can be used in many types of environment. They are especially suitable for applications where small, flexible and easy-to-use arms are required.

The arm is designed for use in electronic environments where there is a risk of electrostatic discharges. The ESD/EX can also be used for certain applications in potentially explosive atmospheres.



Recommended for use in zone 1, 2 and 21, 22.

- Optimal efficiency and low noise provides safe and quiet working environment
- Ceilings, walls and floors or fixed to worktops mountings and cut2fit extension profile gives maximum installation flexibility
- The two outermost arm joints can rotate and swivel through 360°, which gives the unique maneuverability
- The lean, smooth and aesthetic design allows arms to fit in well in any environment without compromising its durability and reliability
- Highly integrated products that save customers' time and costs, as well as providing the reliability and functionality to deliver a better performance

Product name	BenchTop Extraction Arm FX2 75 ESD/EX
Noise level (dB(A))	58 dB(A) at 240 m <sup>3</sup> /h
Installation	[Indoor]
Material	Tubes in anodized aluminium. Joints in conductive PP plastic. Duct connector in conductive EPDM rubber. Minihood in conductive PP plastic.
Fume temperature	max 70°C
Extraction arm diameter (mm)	75
Airflow (m <sup>3</sup> /h)	110 - 240
Colour	Aluminum and black



## BenchTop Extraction Arm FX2 75 ESD/EX

Image	Description	Arm length (m)	Weight (kg)	Model
	FX2-ESD/EX-D75-L1100-Up-Low	1,1	3,2	70603944*
	FX2-ESD/EX-D75-L1100-Down-Low	1,1	3,2	70604144**
	FX2-ESD/EX-D75-L1500-Up-Low	1,5	3,4	70604344*
	FX2-ESD/EX-D75-L1500-Down-Low	1,5	3,4	70604544**

\*Up-Low

\*\*Down-Low

## BenchTop Extraction Arm FX2 75 ESD/EX

	Accessory	Part No
	FX-Bracket kit-D50/75/100-L190	70501144
	FFX2-Bracket kit-D50/75/100-L500	70377042
	FX2-Wall BRKT kit-Flat-L190-Black.	70377044
	FX2-Bench bracket kit-D50/75/100	70501444
	FX-Classic bracket-D50/75/100	70501244
	FX-Cut2fit extension-L1100.	70501344
	FX-Cut2fit extension-L2200	70374600
	FX-Ceiling cover plate	70502644
	FX2-Ceiling cover plate-PLUS	70377045
	FX-Combi hood-ESD/EX-D50/75/100	70500244
	FX-Dome hood-ESD/EX-D50/75/100	70376983
	FX-Metal hood-ESD/EX-D50/75/100	70500544
	FX-Flange hood-ESD/EX-D50/75/100.	70502944
	FX2-Duct connector-ESD/EX-D75	70377039
	FX2-Al duct-L1000-D75/100toD100	70377058
	FX2-Al duct-L2000-D75/100toD100	70377059
	FX-Hose-ESD-D75-L3000-Black-	70377101
	FX-Hose-ESD-D100-L3000-Black- Flexible hose in black conductive PE with 100 mm (4 inch) diameter and 3000 mm (118.11 inch) length. It shall be used with hose support ring to connect hose to arm.	70377102
	FX2-Hose support ring-D75	70377067
	FX2-Hose support ring-D100	70377068

## BenchTop Extraction Arm FX2 75 ESD/EX

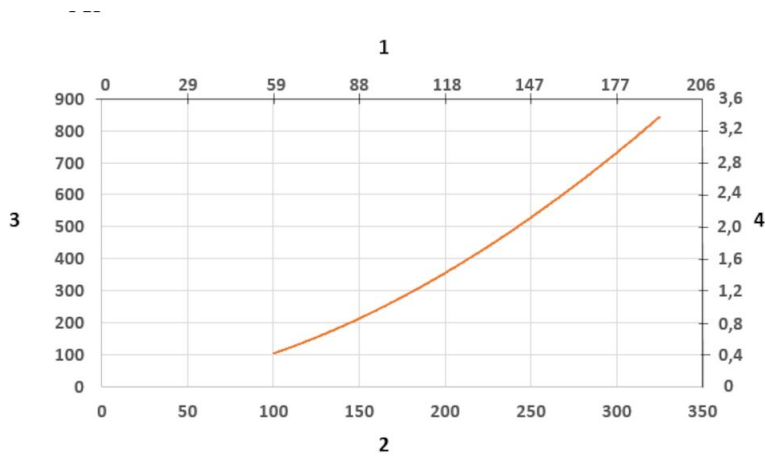

Pressure Drop diagram:

1) X- Axis: Air Flow Rate (cfm)

2) X- Axis: Air Flow Rate (m/h)

3) Y- Axis: Static Pressure Drop (Pa)

4) Y- Axis: Static Pressure Drop (in. wg.)

## BenchTop Extraction Arm FX2 75 ESD/EX

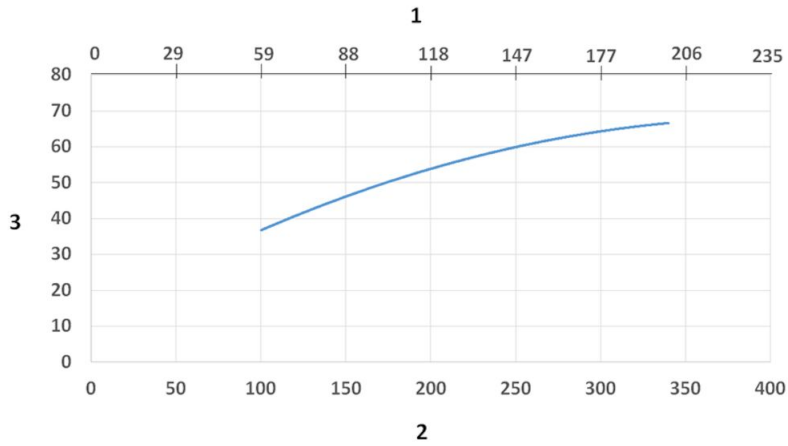

Sound Level diagram:

1) X- Axis: Air Flow Rate (cfm)

2) X- Axis: Air Flow Rate (m/h)

3) Y- Axis: Sound Pressure Level (dB) (A)

## BenchTop Extraction Arm FX2 75 ESD/EX

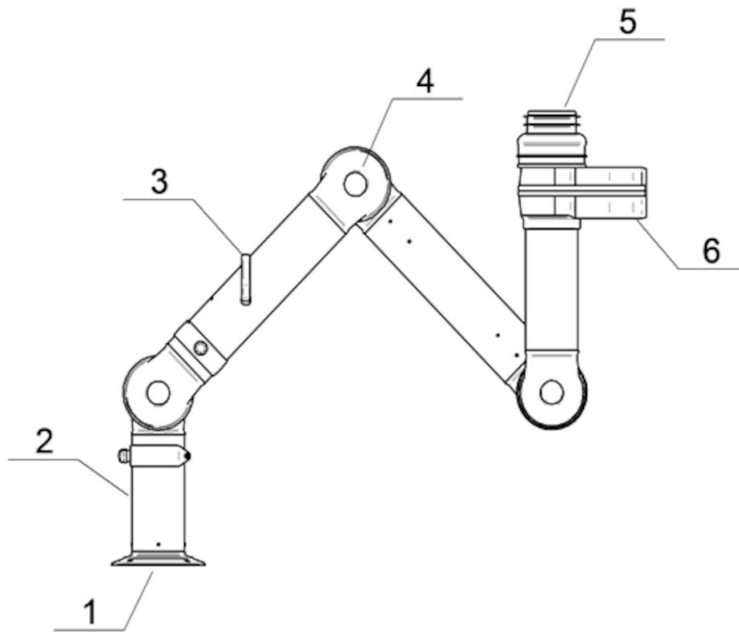

Material:

1) Flange: Conductive PP plastic

2) Tubes: Aluminum, anodized 10 µm

3) Damper adjustment handle: Aluminum: anodized 10 µm  
Internal spring: Stainless steel  
Damper blade: Conductive TP & PP plastic

4) Joints conductive: PP plastic with glass fibre reinforcement  
Plastic rings conductive: PP plastic with glass fibre reinforcement  
Axial locking rings conductive: PP plastic with glass fibre reinforcement  
Adjustment knobs: PA & EDS plastic  
Threaded shaft inside joints: Stainless Steel

5) Duct connector: conductive EPDM Rubber

6) Swivel: Aluminum, conductive powder coating  
Rivets: Aluminum  
Bearings swivel conductive: PP plastic with glass fibre reinforcement

## BenchTop Extraction Arm FX2 75 ESD/EX

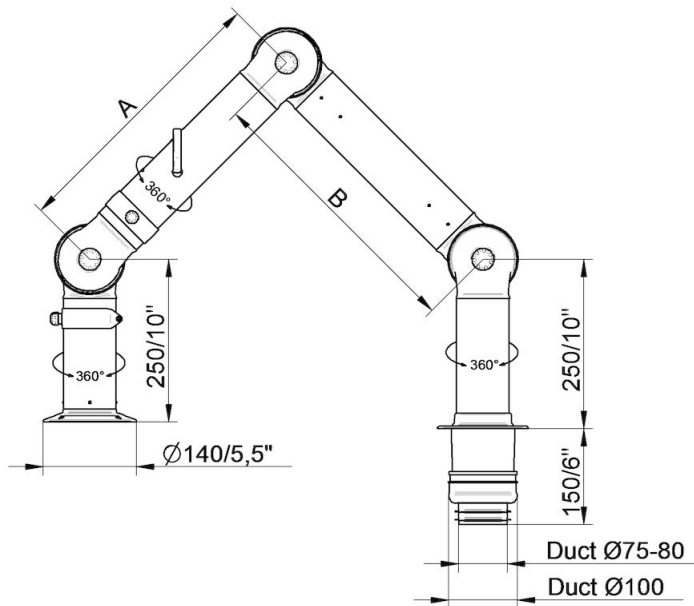

- FX2-ESD/EX-D75-L1100-Down-Through  
Part number: 70604244  
Max. working radius: 1090 mm (42,9 in)  
A: 420 mm (16,5 in)  
B: 420 mm (16,5 in)

- FX2-ESD/EX-D75-L1500-Down-Through  
Part number: 70604644  
Max. working radius: 1450 mm (57,1 in)  
A: 500 mm (19,7 in)  
B: 700 mm (27,5 in)

## BenchTop Extraction Arm FX2 75 ESD/EX

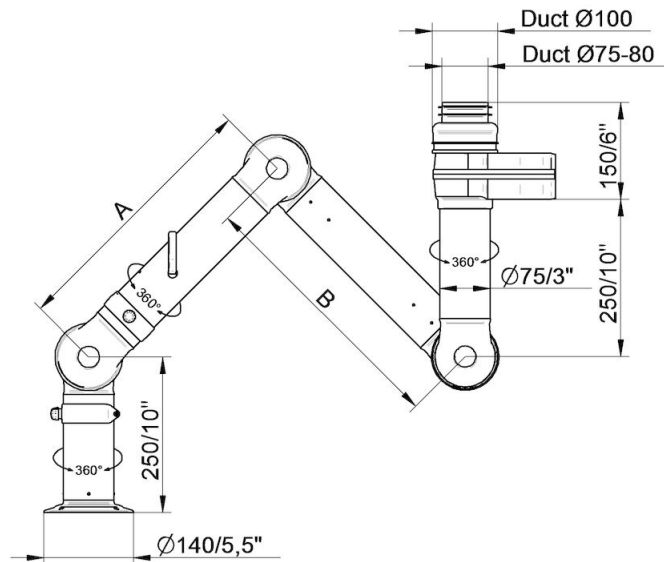

- FX2-ESD/EX-D75-L1100-Up-Low  
Part number: 70603944  
Max. working radius: 1090 mm (42,9 in)  
A: 420 mm (16,5 in)  
B: 420 mm (16,5 in)

- FX2-ESD/EX-D75-L1500-Up-Low  
Part number: 70604344  
Max. working radius: 1450 mm (57,1 in)  
A: 500 mm (19,7 in)  
B: 700 mm (27,5 in)



## BenchTop Extraction Arm FX2 75 ESD/EX

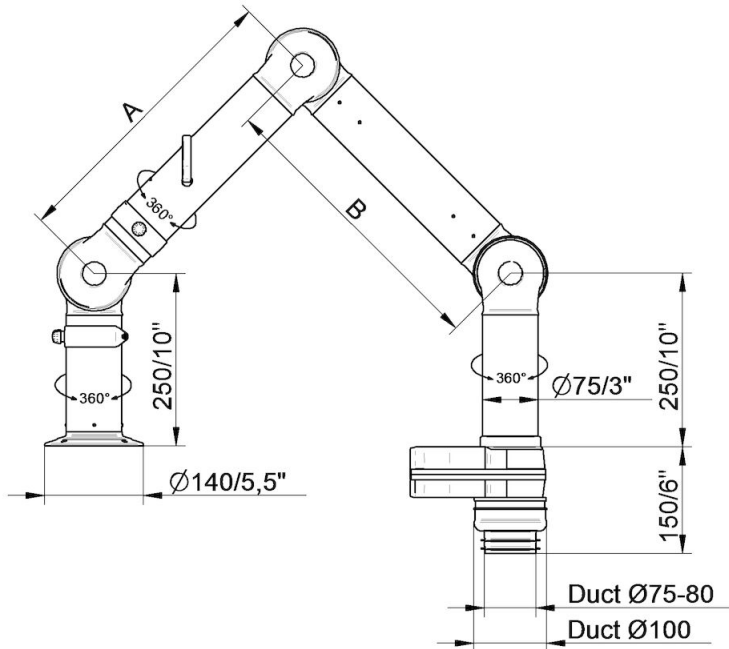

- FX2-ESD/EX-D75-L1100-Down-Low  
Part number: 70604144  
Max. working radius: 1090 mm (42,9 in)  
A: 420 mm (16,5 in)  
B: 420 mm (16,5 in)

- FX2-ESD/EX-D75-L1500-Down-Low  
Part number: 70604544  
Max. working radius: 1450 mm (57,1 in)  
A: 500 mm (19,7 in)  
B: 700 mm (27,5 in)

## BenchTop Extraction Arm FX2 75 ESD/EX

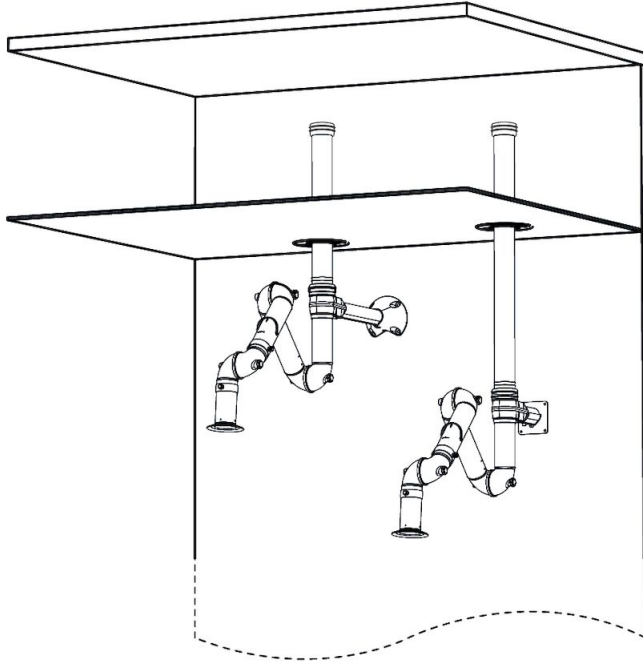

Wall mounting examples:

Left: FX2-Up-Low arm with following accessories:

- FX2-Bracket kit-D-50/75/100-L500
- FX2-Ceiling cover plate-PLUS
- FX2-Alu duct
- FX2-Duct connector-ESD/EX-D100

Right: FX2-Up-Low arm with following accessories:

- FX2-Wall BRKT kit-Flat-L190-Black
- FX2-Ceiling cover plate-PLUS
- FX2-Alu duct
- FX2-Duct connector-ESD/EX-D100

## BenchTop Extraction Arm FX2 75 ESD/EX

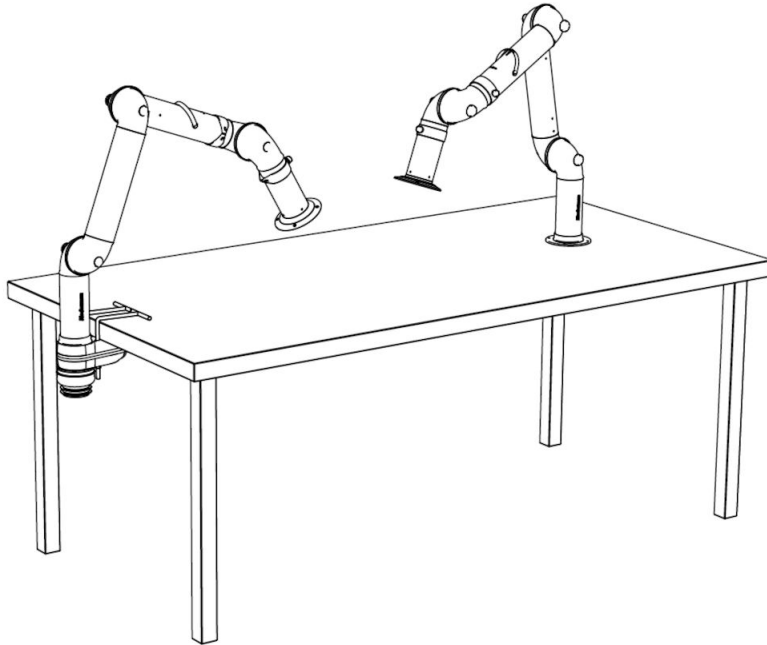

Bench mounting examples:

Left: FX2-Down-Low arm with following accessories:

-FX2-Bench bracket kit-D-50/75/100

Right: FX2-Down-Through arm

## BenchTop Extraction Arm FX2 75 ESD/EX

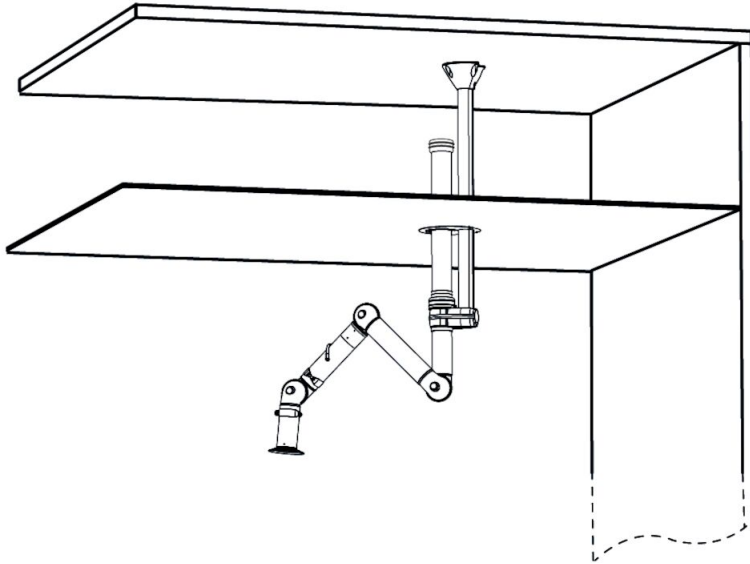

- Ceiling mounting example:  
FX2-Up-Low arm with following accessories:
- FX-Classic bracket
  - FX-Cut2fit extension-L1100
  - FX2-Alu duct
  - FX2-Duct connector-ESD/EX-D100
  - FX-Ceiling cover plate

## BenchTop Extraction Arm FX2 75 ESD/EX

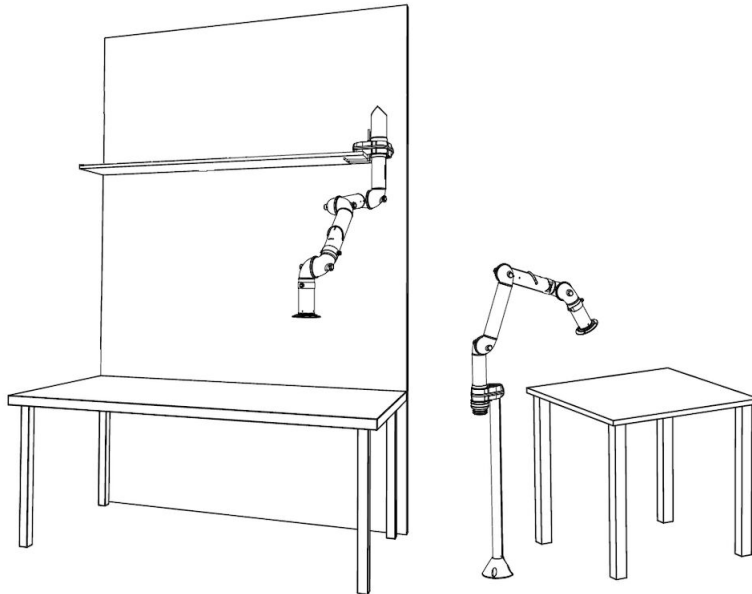

Other mounting examples:

Left: Shelf mounting with FX2-Up-Low arm and following accessories:

-FX2-Bench bracket kit

Right: Floor mounting with FX2-Up-Low arm and following accessories:

-FX-Classic bracket

-FX-Cut2fit extension-L1100