

## Braço extrator de bancada FX2 100 ESD/EX

Solução de melhor custo-benefício para aplicações onde captos compactos, flexíveis e simples sejam necessários.









Os braços Nederman FX2 são feitos de seções leves de alumínio anodizado, com duas ou três juntas ajustáveis de fricção. Oferecendo resistência e durabilidade combinadas com fácil manuseio, elas podem ser usadas em muitos tipos de ambiente. Eles são especialmente adequados para aplicações em que são necessários braços pequenos, flexíveis e fáceis de usar. O braço é projetado para uso em ambientes eletrônicos, onde existe o risco de descargas eletrostáticas. O ESD / EX também pode ser usado para certas aplicações em atmosferas potencialmente explosivas. Recomendado para uso nas zonas 1, 2 e 21, 22.

- Excelente eficiência e baixo nível de ruído garantem um ambiente de trabalho seguro e agradável.
- Suportes para fixação em teto, parede, pisos e bancadas, e os perfis de extensão Cut2fit garantem máxima flexibilidade de instalação.
- As justas externas permitem rotação 360° das seções do braço, garantindo total e exclusiva manobrabilidade.
- O desenho leve, suave e estético permite que os braços se adequem a qualquer ambiente sem comprometer sua durabilidade e confiabilidade.
- Produtos totalmente integrados que economizam tempo e custos, além de prover alta confiabilidade e funcionalidade.

Nome do Produto	Braço extrator de bancada FX2 100 ESD/EX
Nível de ruído (dB(A))	62 dB(A) at 450 m <sup>3</sup> /h
Instalação	Interior
Material	Tubes in anodized aluminium. Joints in conductive PP plastic. Duct connector in conductive EPDM rubber. Minihood in conductive PP plastic.
Temperatura dos fumos	max 70°C
Diâmetro do braço de extração (mm)	100
Caudal (m <sup>3</sup> /h)	200 - 450



## Braço extrator de bancada FX2 100 ESD/EX

[image]	Descrição	Comprimento do braço (m)	Cor	Peso (kg)	[model]
	FX2-ESD/EX-D100-L1200-Up/Down-Low	1,2	Aluminum and black	4,8	70606544*
	FX2-ESD/EX-D100-L1200-Up/Down-Thru	1,2	Aluminum and black	4,1	70606744*
	FX2-ESD/EX-D100-L1800-Up-Low	1,8	aluminum adn black	5,9	70606844**
	FX2-ESD/EX-D100-L1800-Down-Low	1,8	Aluminum and black	5,9	70607044***
	FX2-ESD/EX-D100-L1800-Down-Through	1,8	Aluminum and black	5,2	70607144****
	FX2-ESD/EX-D100-L2400-Up-Low	2,4	Aluminum and black	6,9	70607244**

















\*Up/Down-Low

\*\*Up-Low

\*\*\*Down-Low

\*\*\*\*Down-Through

## Braço extrator de bancada FX2 100 ESD/EX

	[accessory]	[partno]
	Suporte FX-Bracket kit-D50/75/100-L190.	70501144
	Suporte FX2-Bracket kit-D50/75/100-L500	70377042
	Suporte de bancada FX2 D50/75/100	70501444
	Suporte FX-Classic D50/75/100	70501244
	Extensão FX-Cut2fit L1100.	70501344
	Extensão FX-Cut2fit L2200.	70374600
	Tampa FX-Ceiling cover plate	70502644
	Tampa FX-Ceiling cover plate PLUS	70377045
	Suporte FX2-Wall BRKT FLAT-L190-Black.	70377044
	Coifa FX-Dome ESD/EX-D50/75/100.	70376983
	Coifa FX-Combi ESD/EX-D50/75/100	70500244
	Coifa FX-Metal ESD/EX-D50/75/100	70500544
	Coifa FX-Flange ESD-D50/75/100	70502944
	Conector FX2-Duct connector-ESD/EX-D75	70377041
	Duto FX2-Al duct-L1000-D75/100toD100	70377058
	Duto FX2-Al duct-L2000-D75/100toD100	70377059
	FX2-Hose support ring-D100	70377068
	FX2-Hose support ring-D125	70377069

## Braço extrator de bancada FX2 100 ESD/EX

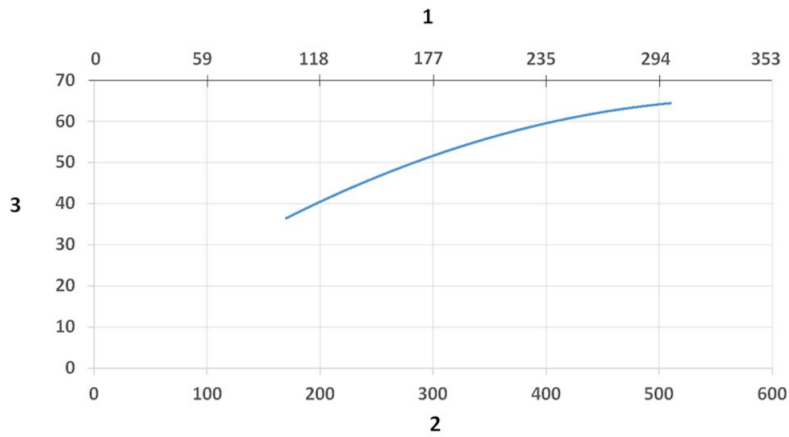

Sound Level diagram:

1) X- Axis: Air Flow Rate (cfm)

2) X- Axis: Air Flow Rate (m/h)

3) Y- Axis: Sound Pressure Level (dB) (A)

## Braço extrator de bancada FX2 100 ESD/EX

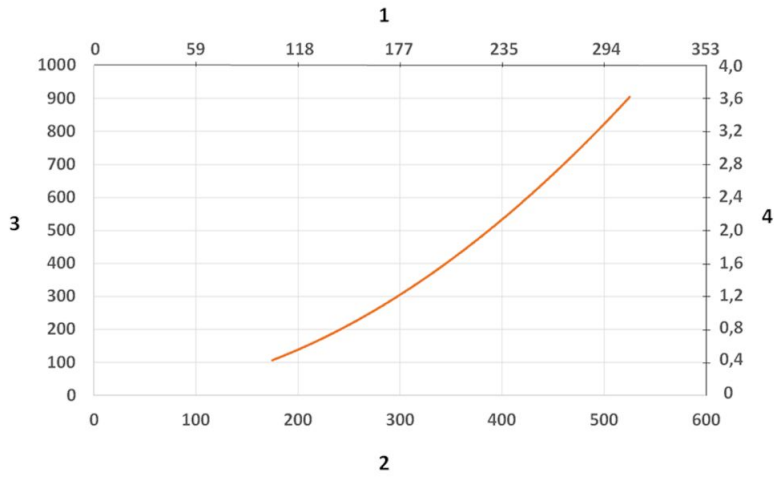

Pressure Drop diagram:

- 1) X- Axis: Air Flow Rate (cfm)
- 2) X- Axis: Air Flow Rate (m/h)

- 3) Y- Axis: Static Pressure Drop (Pa)
- 4) Y- Axis: Static Pressure Drop (in. wg.)

## Braço extrator de bancada FX2 100 ESD/EX

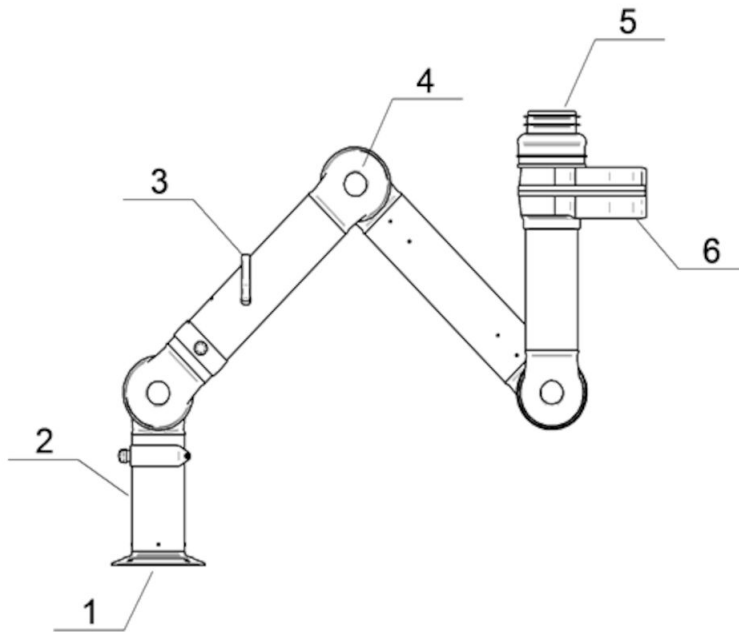

Material:

1) Flange: Conductive PP plastic

2) Tubes: Aluminum, anodized 10 µm

3) Damper adjustment handle: Aluminum: anodized 10 µm  
Internal spring: Stainless steel  
Damper blade: Conductive TP & PP plastic

4) Joints conductive: PP plastic with glass fibre reinforcement  
Plastic rings conductive: PP plastic with glass fibre reinforcement  
Axial locking rings conductive: PP plastic with glass fibre reinforcement  
Adjustment knobs: PA & EDS plastic  
Threaded shaft inside joints: Stainless Steel

5) Duct connector: conductive EPDM Rubber

6) Swivel: Aluminum, conductive powder coating  
Rivets: Aluminum  
Bearings swivel conductive: PP plastic with glass fibre reinforcement

## Braço extrator de bancada FX2 100 ESD/EX

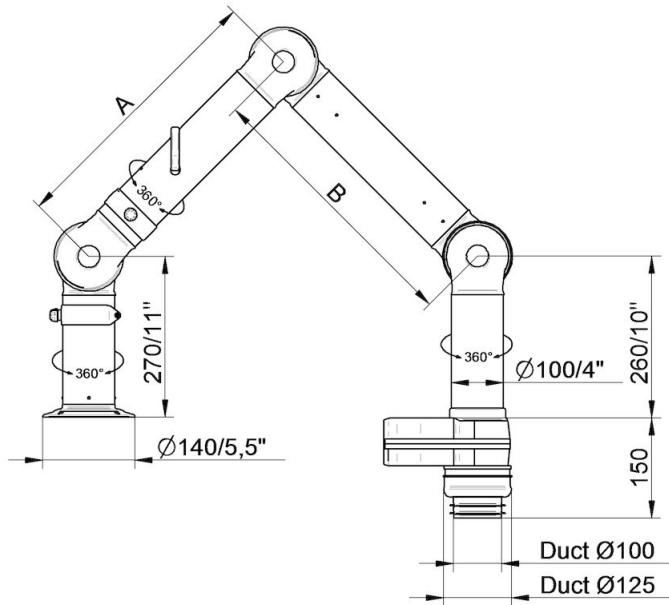

- FX2-ESD/EX-D100-L1200-Up/Down-Low  
Part number: 70606544  
Max. working radius: 1170 mm (46,1 in)  
A: 450 mm (17,7 in)  
B: 450 mm (17,7 in)

- FX2-ESD/EX-D100-L1800-Down-Low  
Part number: 70607044  
Max. working radius: 1770 mm (69,7 in)  
A: 750 mm (29,5 in)  
B: 750 mm (29,5 in)

## Braço extrator de bancada FX2 100 ESD/EX

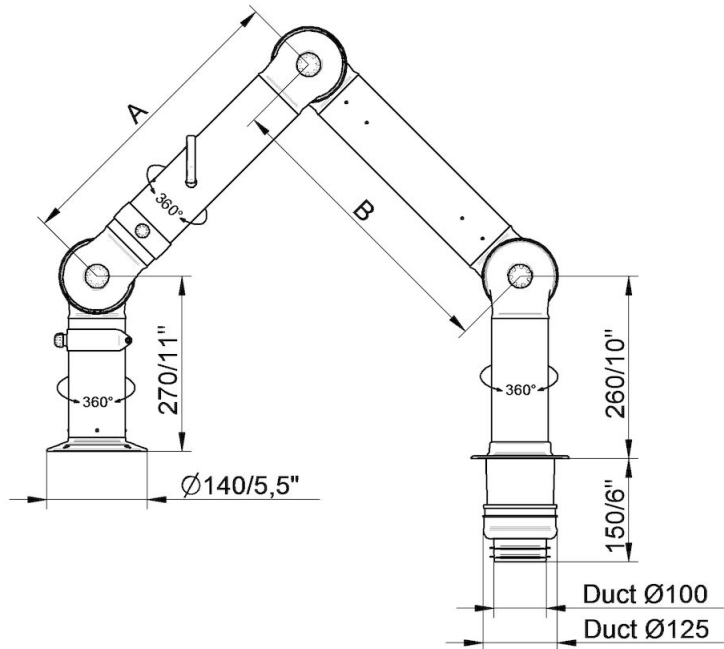

- FX2-ESD/EX-D100-L1200-Up/Down-Thru  
Part number: 70606744  
Max. working radius: 1170 mm (46,1 in)  
A: 450 mm (17,7 in)  
B: 450 mm (17,7 in)

- FX2-ESD/EX-D100-L1800-Down-Through  
Part number: 70607144  
Max. working radius: 1770 mm (69,7 in)  
A: 750 mm (29,5 in)  
B: 750 mm (29,5 in)



## Braço extrator de bancada FX2 100 ESD/EX

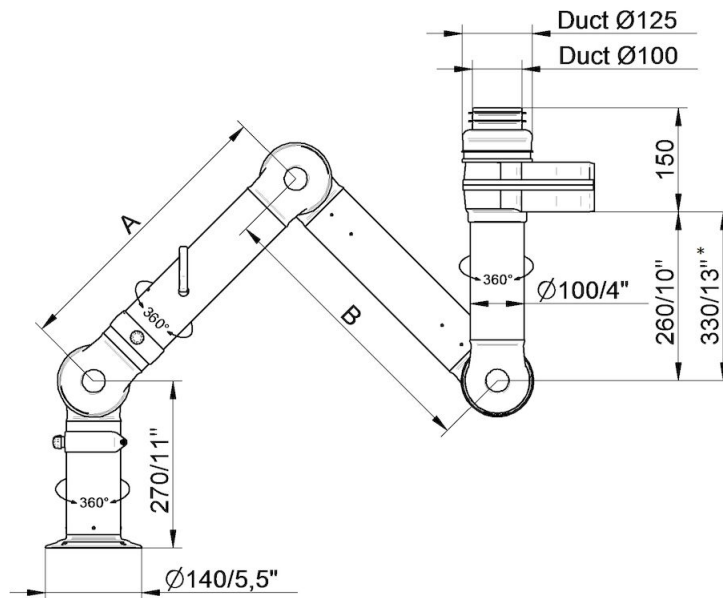

- FX2-ESD/EX-D100-L1200-Up/Down-Low  
Part number: 70606544  
Max. working radius: 1170 mm (46,1 in)  
A: 450 mm (17,7 in)  
B: 450 mm (17,7 in)

- FX2-ESD/EX-D100-L1800-Up-Low  
Part number: 70606844  
Max. working radius: 1770 mm (69,7 in)  
A: 750 mm (29,5 in)  
B: 750 mm (29,5 in)

\*

- FX2-ESD/EX-D100-L2400-Up-Low  
Part number: 70607244  
Max. working radius: 2290 (90,16 in)  
A: 1010 mm (39,7 in)  
B: 1010 mm (39,7 in)

## Braço extrator de bancada FX2 100 ESD/EX

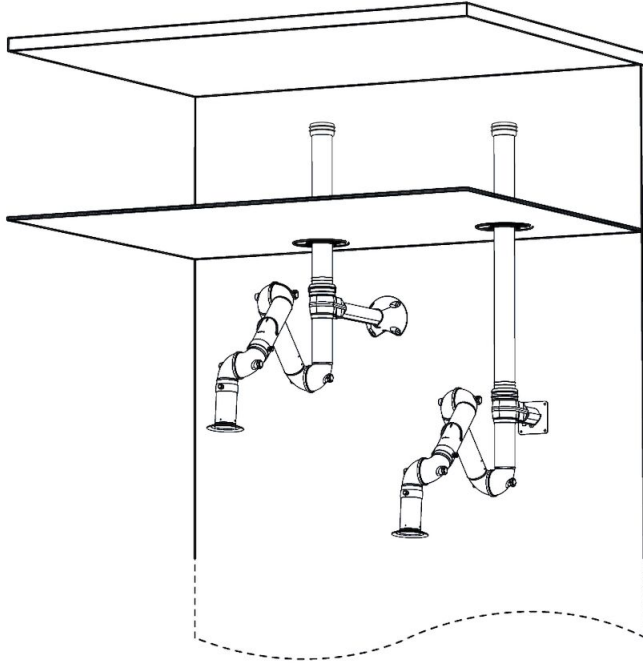

Wall mounting examples:

Left: FX2-Up-Low arm with following accessories:

- FX2-Bracket kit-D50/75/100-L500
- FX2-Ceiling cover plate-PLUS
- FX2-Alu duct
- FX2-Duct connector-ESD/EX-D100

Right: FX2-Up-Low arm with following accessories:

- FX2-Wall BRKT kit-Flat-L190-Black
- FX2-Ceiling cover plate-PLUS
- FX2-Alu duct
- FX2-Duct connector-ESD/EX-D100

## Braço extrator de bancada FX2 100 ESD/EX

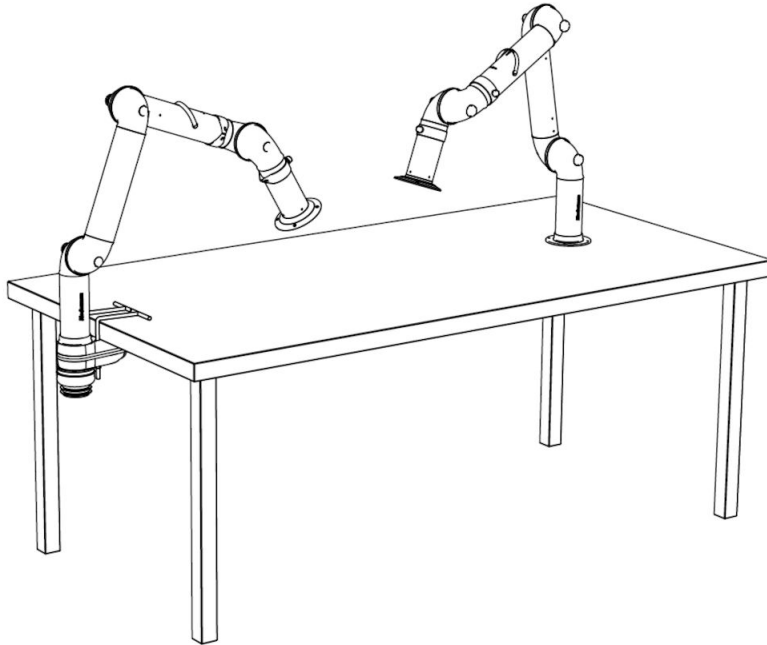

Bench mounting examples:

Left: FX2-Down-Low arm with following accessories:

-FX2-Bench bracket kit-D50/75/100

Right: FX2-Down-Through arm

## Braço extrator de bancada FX2 100 ESD/EX

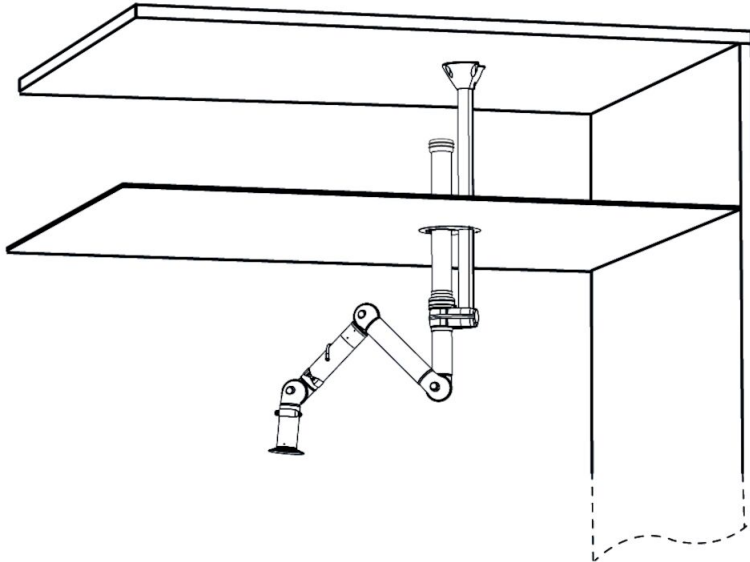

- Ceiling mounting example:  
FX2-Up-Low arm with following accessories:
- FX-Classic bracket
  - FX-Cut2fit extension-L1100
  - FX2-Alu duct
  - FX2-Duct connector-ESD/EX-D100
  - FX-Ceiling cover plate

## Braço extrator de bancada FX2 100 ESD/EX

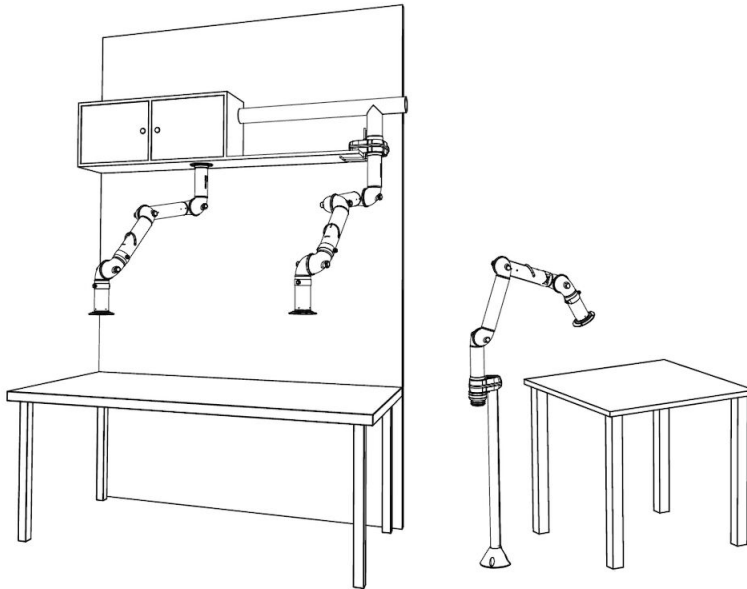

Other mounting examples:

Left: Overbench cabinet mounting with FX2-Up/Down-Through arm

Middle: Shelf mounting with FX2-Up-Low arm and following accessories:

-FX2-Bench bracket kit

Right: Floor mounting with FX2-Up-Low arm and following accessories:

-FX-Classic bracket

-FX-Cut2fit extension-L1100