

## Tezgâh Üstü Ekstraksiyon Kolu FX2 100 ESD/EX

Küçük, esnek ve kullanımı kolay kolların gerekli olduğu uygulamalarda havada dolaşan tehlikeli kirletici maddelerin ekstraksiyonunun en ideal ve en tasarruflu çözümüdür.



Nederman FX2 kolları iki veya üç adet ayarlanabilir kompozit sürtünme birleşimine sahip hafif ağırlıkta eloksallı alüminyum kesitlerden imal edilmiştir. Kolay kullanımla birlikte sağlamlık ve dayanıklılık sunan bu ürünler birçok tipte ortamda kullanılabilirler. Özellikle küçük, esnek ve kullanımı kolay kolların gerekli olduğu uygulamalar için uygundur.







Bu kol, elektrostatik deşarj riski olan elektronik ortamlarda kullanılmak üzere tasarlanmıştır. Ayrıca ESD / EX belirli uygulamalar için potansiyel olarak patlama tehlikesi bulunan atmosferlerde de kullanılabilir.

- İdeal etkinlik ve düşük gürültü seviyesi güvenli ve sessiz çalışma ortamı sağlar.
- Tavanlara, duvarlara ve zeminlere veya tezgah üstüne montajlarına sabitlenmeleri ve uygun kesim uzatma profili maksimum montaj esnekliği sunar.
- En dıştaki iki kol birleşimi döner tertibatı 360° döndürebilir ki bu da eşsiz manevra kabiliyetini sağlar.
- Sade, pürüzsüz ve estetik bir tasarım kolların dayanıklılıklarından ve güvenilirliklerinden herhangi bir ödün vermeksizin her türlü ortamda en iyi şekilde uyum sağlamasına olanak tanır.
- Müşteriler için zaman ve maliyet tasarrufu sağlayan ve daha iyi bir performans sunmak için güvenilirlik ve işlevsellik sunan son derece entegre ürünler.

Medya	Tezgâh Üstü Ekstraksiyon Kolu FX2 100 ESD/EX
Ses Düzeyi (dB(A))	450 m <sup>3</sup> /saatte 62 dB(A)
Kurulum	[Indoor]
Materyal	Eloksallı alüminyum borular. İletken PP plastiklerde birleşimler. İletken EPDM lastik boru bağlantısı. PP plastikte mini hazne.
Dumam ısısı	max 70°C
Emiş kolu ölçüsü (mm)	100
Hava Debisi (m <sup>3</sup> /h)	200 - 450



## Tezgâh Üstü Ekstraksiyon Kolu FX2 100 ESD/EX

[image]	Bilgi Dökümanı ismi	Kol uzunluğu (m)	Renk	Ağırlık (kg)	[model]
	FX2-ESD/EX-D100-L1200- Yukari/Aşağı-Alt	1,2	Aluminum and black	4,8	70606544*
	FX2-ESD/EX-D100-L1200- Yukari/Aşağı-Boyunca	1,2	Aluminum and black	4,1	70606744*
	FX2-ESD/EX-D100-L1800- Yukari-Alt	1,8	aluminum adn black	5,9	70606844**
	FX2-ESD/EX-D100-L1800- Aşağı-Alt	1,8	Aluminum and black	5,9	70607044***
	FX2-ESD/EX-D100-L1800- Aşağı-Boyunca	1,8	Aluminum and black	5,2	70607144****
	FX2-ESD/EX-D100-L2400- Yukari-Alt	2,4	Aluminum and black	6,9	70607244**













\*Up/Down-Low

\*\*Up-Low

\*\*\*Down-Low

\*\*\*\*Down-Through

## Tezgâh Üstü Ekstraksiyon Kolu FX2 100 ESD/EX

	[accessory]	[partno]
	FX-braket kiti-D50/75/100-L190	70501144
	FX2-braket kiti-D50/75/100-L500	70377042
	FX2-tezgah braket kiti-D50/75/100	70501444
	FX-klasik braket-D50/75/100	70501244
	FX-uygun Kesim uzantı-L1100.	70501344
	FX-Uygun Kesim uzantı-L2200	70374600
	FX-Tavan kapatma plakası.	70502644
	FX2-Tavan kapatma plakası-PLUS	70377045
	FX2-duvar BRKT kit-düz-L190-Siyah.	70377044
	FX-Kubbe gövde-ESD/EX-D50/75/100	70376983
	FX-Kombi gövde-ESD/EX-D50/75/100	70500244
	FX-metal gövde-ESD/EX-D50/75/100	70500544
	FX-Flanş gövde-ESD/EX-D50/75/100	70502944
	FX2-Kanal konnektörü -ESD/EX-D100	70377041
	FX2-AI Kanal-L1000-D75/100toD100	70377058
	FX2-AI Kanal-L2000-D75/100toD100	70377059
	FX-Hortum-ESD-D100-L3000-Siyah-Siyah iletken PE'den imal edilmiş, 100 mm (4 inç) çapa ve 3000 mm (118.11 inç) uzunluğa sahip esnek hortum. Hortumun kola bağlanması için hortum destek halkası ile kullanılmalıdır.	70377102
	FX-Hortum-ESD-D125-L5000-Siyah-Siyah iletken PE'den imal edilmiş, 125 mm (5 inç) çapa ve 5000 mm (195.85 inç) uzunluğa sahip esnek hortum. Hortumun kola bağlanması için hortum destek halkası ile kullanılmalıdır.	70377103
	FX2-Hose support ring-D100	70377068
	FX2-Hose support ring-D125	70377069

## Tezgâh Üstü Ekstraksiyon Kolu FX2 100 ESD/EX

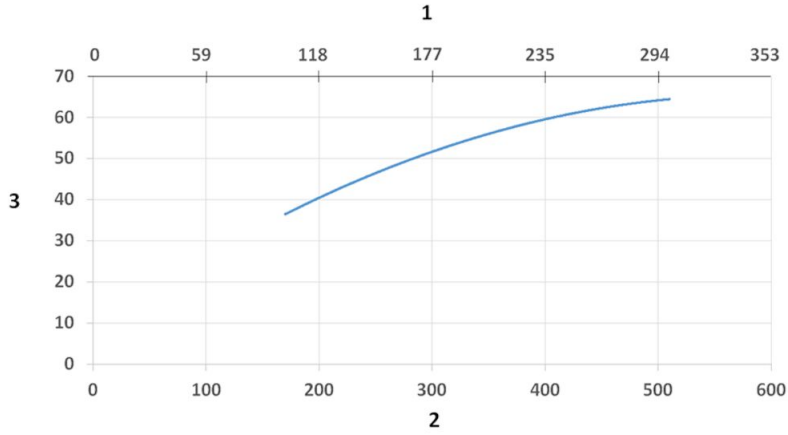

Sound Level diagram:

1) X- Axis: Air Flow Rate (cfm)

2) X- Axis: Air Flow Rate (m/h)

3) Y-Axis: Sound Pressure Level (dB) (A)

## Tezgâh Üstü Ekstraksiyon Kolu FX2 100 ESD/EX

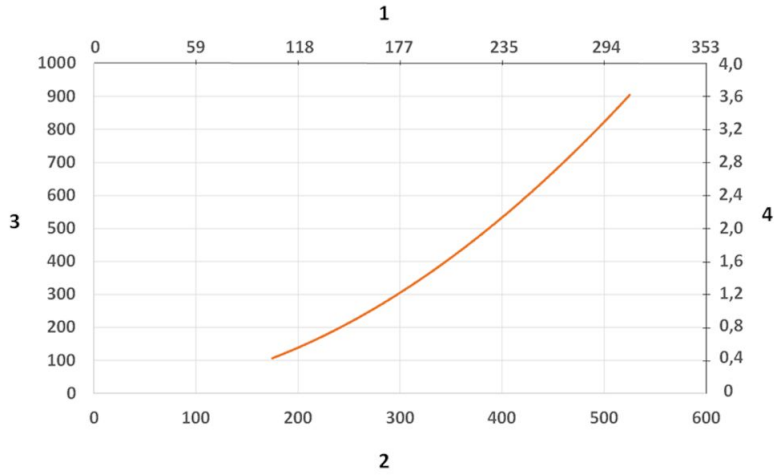

Pressure Drop diagram:

1) X- Axis: Air Flow Rate (cfm)

2) X- Axis: Air Flow Rate (m/h)

3) Y- Axis: Static Pressure Drop (Pa)

4) Y- Axis: Static Pressure Drop (in. wg.)

## Tezgâh Üstü Ekstraksiyon Kolu FX2 100 ESD/EX

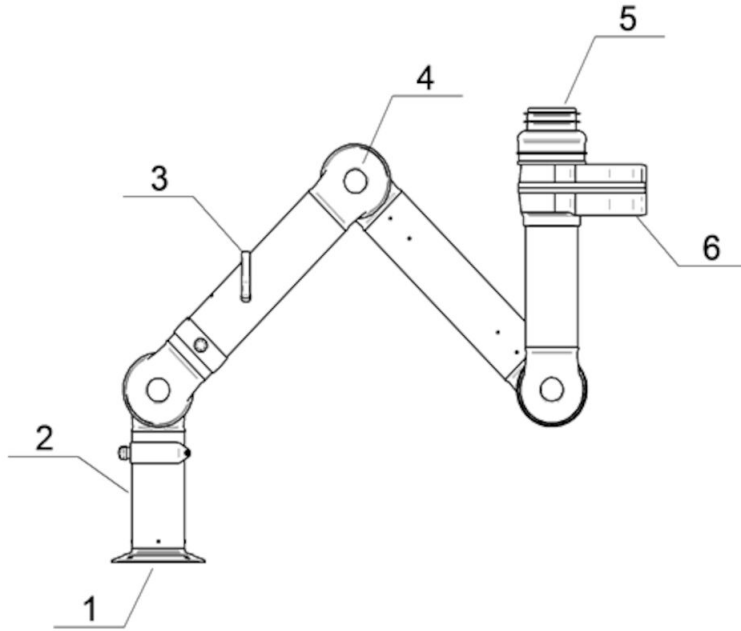

Material:

1) Flange: Conductive PP plastic

2) Tubes: Aluminum, anodized 10 µm

3) Damper adjustment handle: Aluminum: anodized 10 µm  
Internal spring: Stainless steel  
Damper blade: Conductive TP & PP plastic

4) Joints conductive: PP plastic with glass fibre reinforcement  
Plastic rings conductive: PP plastic with glass fibre reinforcement  
Axial locking rings conductive: PP plastic with glass fibre reinforcement  
Adjustment knobs: PA & EDS plastic  
Threaded shaft inside joints: Stainless Steel

5) Duct connector: conductive EPDM Rubber

6) Swivel: Aluminum, conductive powder coating  
Rivets: Aluminum  
Bearings swivel conductive: PP plastic with glass fibre reinforcement

## Tezgâh Üstü Ekstraksiyon Kolu FX2 100 ESD/EX

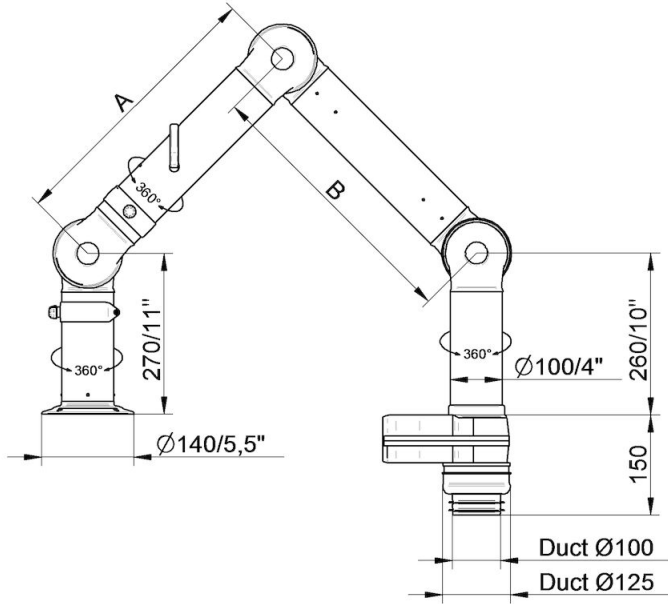

- FX2-ESD/EX-D100-L1200-Up/Down-Low  
Part number: 70606544  
Max. working radius: 1170 mm (46,1 in)  
A: 450 mm (17,7 in)  
B: 450 mm (17,7 in)

- FX2-ESD/EX-D100-L1800-Down-Low  
Part number: 70607044  
Max. working radius: 1770 mm (69,7 in)  
A: 750 mm (29,5 in)  
B: 750 mm (29,5 in)

## Tezgâh Üstü Ekstraksiyon Kolu FX2 100 ESD/EX

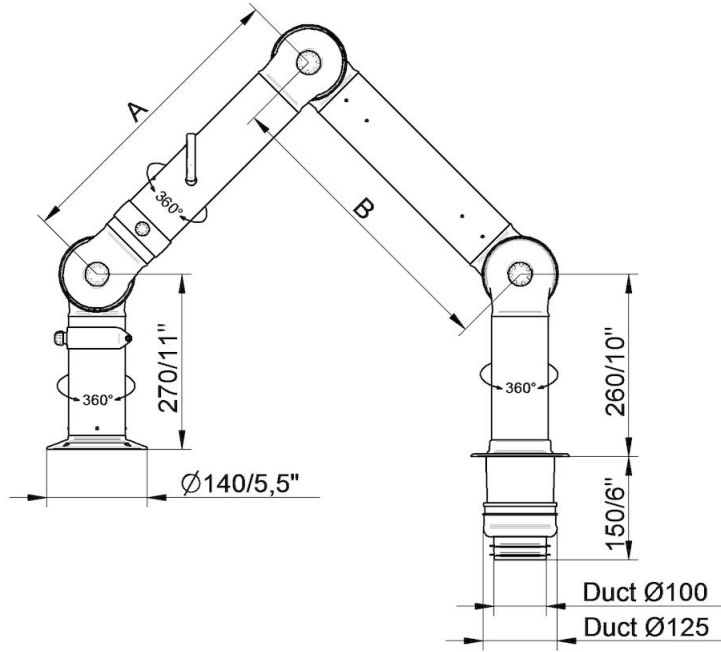

- FX2-ESD/EX-D100-L1200-Up/Down-Thru  
Part number: 70606744  
Max. working radius: 1170 mm (46,1 in)  
A: 450 mm (17,7 in)  
B: 450 mm (17,7 in)

- FX2-ESD/EX-D100-L1800-Down-Through  
Part number: 70607144  
Max. working radius: 1770 mm (69,7 in)  
A: 750 mm (29,5 in)  
B: 750 mm (29,5 in)



## Tezgâh Üstü Ekstraksiyon Kolu FX2 100 ESD/EX

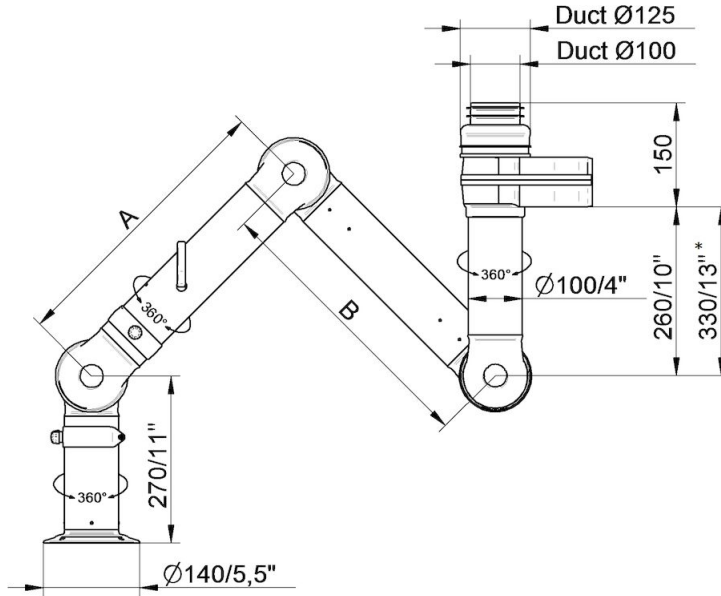

- FX2-ESD/EX-D100-L1200-Up/Down-Low  
Part number: 70606544  
Max. working radius: 1170 mm (46,1 in)  
A: 450 mm (17,7 in)  
B: 450 mm (17,7 in)

- FX2-ESD/EX-D100-L1800-Up-Low  
Part number: 70606844  
Max. working radius: 1770 mm (69,7 in)  
A: 750 mm (29,5 in)  
B: 750 mm (29,5 in)

\*

- FX2-ESD/EX-D100-L2400-Up-Low  
Part number: 70607244  
Max. working radius: 2290 (90,16 in)  
A: 1010 mm (39,7 in)  
B: 1010 mm (39,7 in)

## Tezgâh Üstü Ekstraksiyon Kolu FX2 100 ESD/EX

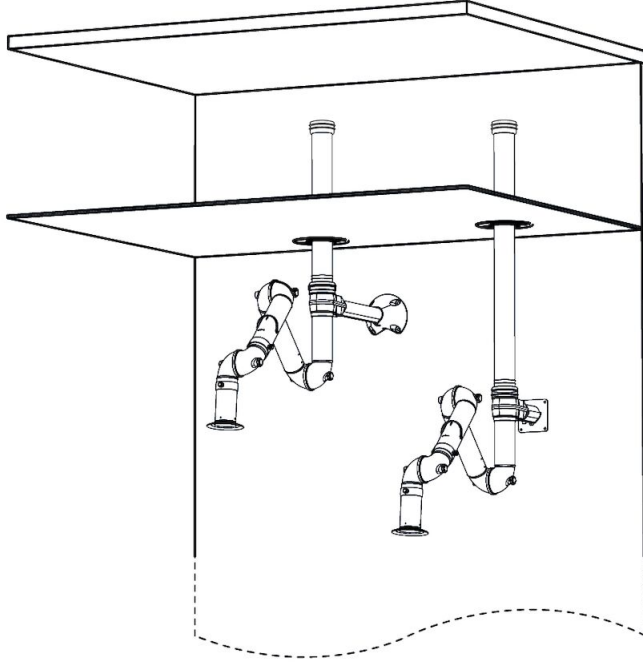

Wall mounting examples:

Left: FX2-Up-Low arm with following accessories:

- FX2-Bracket kit-D50/75/100-L500
- FX2-Ceiling cover plate-PLUS
- FX2-Alu duct
- FX2-Duct connector-ESD/EX-D100

Right: FX2-Up-Low arm with following accessories:

- FX2-Wall BRKT kit-Flat-L190-Black
- FX2-Ceiling cover plate-PLUS
- FX2-Alu duct
- FX2-Duct connector-ESD/EX-D100

## Tezgâh Üstü Ekstraksiyon Kolu FX2 100 ESD/EX

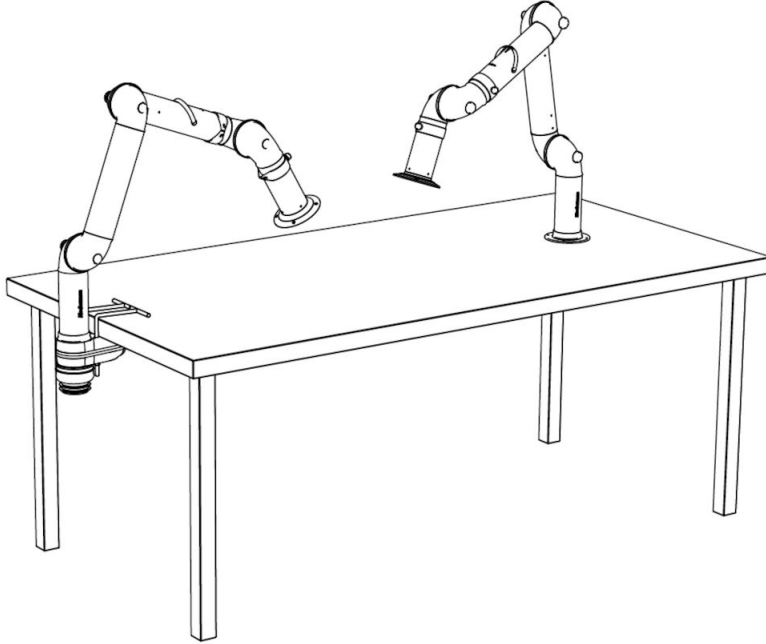

Bench mounting examples:

Left: FX2-Down-Low arm with following accessories:

-FX2-Bench bracket kit-D50/75/100

Right: FX2-Down-Through arm

## Tezgâh Üstü Ekstraksiyon Kolu FX2 100 ESD/EX

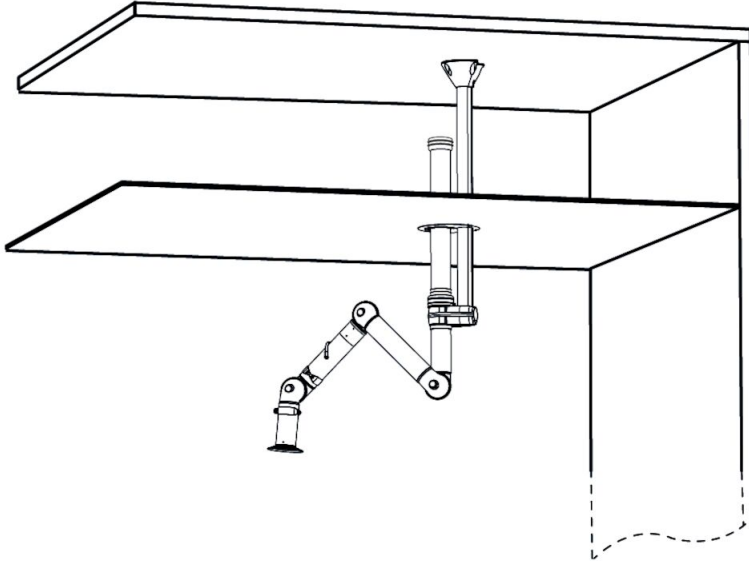

- Ceiling mounting example:  
FX2-Up-Low arm with following accessories:
- FX-Classic bracket
  - FX-Cut2fit extension-L1100
  - FX2-Alu duct
  - FX2-Duct connector-ESD/EX-D100
  - FX-Ceiling cover plate

## Tezgâh Üstü Ekstraksiyon Kolu FX2 100 ESD/EX

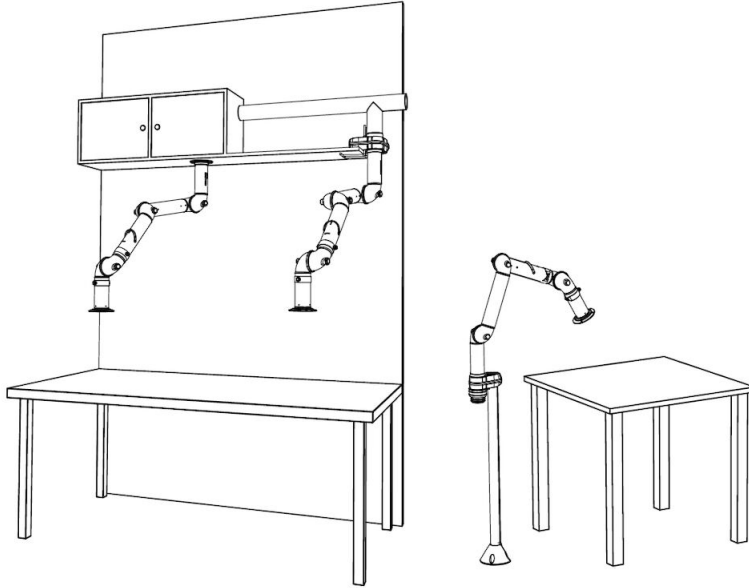

Other mounting examples:

Left: Overbench cabinet mounting with FX2-Up/Down-Through arm

Middle: Shelf mounting with FX2-Up-Low arm and following accessories:

-FX2-Bench bracket kit

Right: Floor mounting with FX2-Up-Low arm and following accessories:

-FX-Classic bracket

-FX-Cut2fit extension-L1100