

FlexFilter

Modular designed dust collector



Dust collector with 2-stage filtration. Central inlet with velocity reducer. Fully automatic filter cleaning. Can easily be equipped with a great variety of filter materials, bins, emptying systems, etc. Standard equipped with circular bags of polypropylene.

Product name	FlexFilter
Protection class	IP65 (cleaning valve) Painting: ISO 12944, class C2M
Compressed air requirement	6 - 10 bar (dry)
Compressed air consumption	0,6 NI/cleaning pulse (intermitent 700 NL/min)
Installation	[Outdoor], [Indoor]
Material	Sheet metal
Filter cleaning method	Reverse air pulse
Application	[dust], [granulate], [grit], [fumes]
Dustbin volume (l)	70 (per filter)
Filter Area (m ²)	12 (per filter)
Capacity (max airflow m ³ /h)	Single 1600 Single RF 1800 Twin 3200 Twin RF 3600
Operating Temperature	Ambient air -20 to +40 Deg. C. (with anti freeze in compressed air) Process air max +60 Deg. C.
Filter type	[bag]
Note	With reverse flow filter cleaning







Granulate Grit Fumes Dust

FlexFilter

Image	Description	Number of filter elements	Filter material	Weight (kg)	Model
	FlexFilter single	1	Polypropylene (Standard) Class M according to EN 60335-2-69	195	40118600
	FlexFilter single RF	1	PTFE Class M according to EN 60335-2-69	215	40118601*
	FlexFilter single with automating emptying of bin and high stand	1	Polypropylene (Standard) Class M according to EN 60335-2-69	302	40118604
	FlexFilter twin	2	Polypropylene (Standard) Class M according to EN 60335-2-69	367	40118605
	FlexFilter twin RF	2	PTFE Class M according to EN 60335-2-69	375	40118606*
	FlexFilter single Cyclone		None	188	40118618

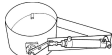
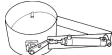
*With reverse flow filter cleaning

FlexFilter

	Accessory	Part No
	Housing module A standard	40118020
	Top module A	40118510
	Filter module cyclone insert	40119751
	Fire alarm complete.	40116540
	TVS200 DA	40117640
	TVS200 NC	40117650
	Control Filter cpl	40376897
	Control Filter cpl HEPA	40376898
	Diff. pressure switch 3-15 kPa NC	40375273
	Connection pipe	40117630
	Bag filter, sparepart	40119850
	HVCP 37kW Std Insight EU - IoT ready	40124522
	HVCP 45kW Std Insight EU - IoT ready	40124521
	HVCP 45kW Std - IoT upgradeable	40124523
	HVCP 55kW Std - IoT upgradeable	40124526
	HVCP 37kW Std - IoT upgradeable	40124524
	Bag filter PTFE sparepart	40119860
	Dust bin level alarm / Bin Level Indicator. BLI 10-40VDC Compl.	40780710

FlexFilter

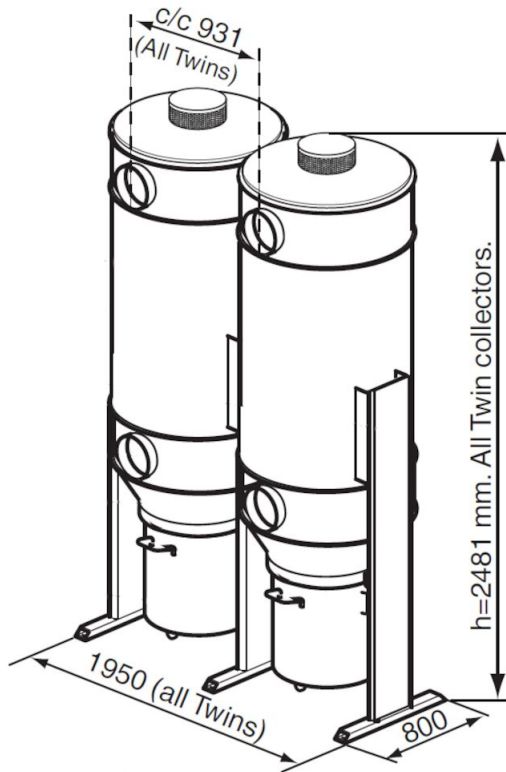

FlexFilter

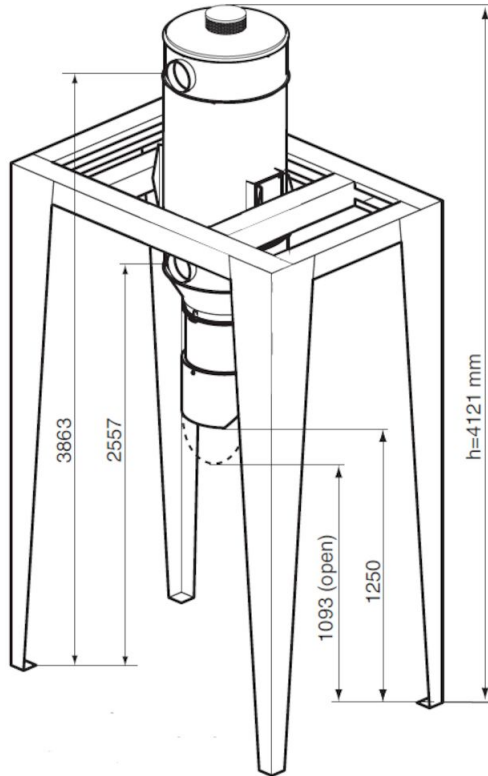

FlexFilter

