

FlexFilter EX

A state of the art filter system to meet your current and future needs



The Flexfilter EX is manufactured to withstand overpressure from a potential explosion and is equipped with an explosion relief panel. The harmful effects of an explosion are minimized by venting the overpressure and flame propagation via the relief panel to a safe area. The dust collector is fully earth bonded in all modular components. All electric equipment is EX classified for combustible dust. Options are available for the collected dust from either a standard 70L (18 gal) collection bin complete with bin balance kit to allow the use of conductive plastic sack for ease of removal of the collected dust or fully automatic empty device with fully conductive bulk bag with earth cables for larger installations. A control filter comes as standard to allow the use of non-EX rated vacuum units.

Permitted materials:

It is of outmost importance to know the properties of the extracted material. The FlexFilter EX is intended to be a part of an extraction system collecting material with the following properties:

- Dust explosion class: St1 and St2
- Pmax: ≤10 bar
- MIE (Minimum Ignition Energy) 3 mJ
- MIT (Minimum Ignition Temperature) > 205 °C

Product marking:

The FlexFilter EX is ATEX classified according to directive 2014/34/EU and marked:CE Ex II 3D Ex c T=130 °C

- A state of the art filter system to meet your current and future needs
- Equipped with an explosion relief panel
- Standard 70L bin with antistatic plastic bag, or conductive bulk bag fitted to a fully automatic emptying device

Product name	FlexFilter EX
Standard	2014/34/EC
Installation	[Outdoor]
Material	Sheet metal
Suitable for combustible dust	True
Filter cleaning method	[ReverseAirPulse]
Application	[dust], [granulate], [grit], [fumes]
Dustbin volume (l)	70 l (not for high Stand)
Filter Area (m²)	12 (per filter)
Capacity (max airflow m3/h)	1600 (per filter)
Filter type	[bag]
Filter material	Conductive (<10 ⁸ Ω) polyester. Class M according to EN 60335-2-69







Granulate Grit Fumes Dust



FlexFilter EX

FlexFilter EX

[Image]	Description	Number of filter elements	Weight (kg)	[model]
	FlexFilter EX with 70l dust bin	1	255	40118943
	FlexFilter Twin EX with 2x70 l dustbin	2	485	40118983
	FlexFilter EX High Stand with feed out device and bulk bags for dust collection. Prepared for legs.	1	450	40118942
	The FlexFilter Twin EX High Stand with feed out device and bulk bags for dust collection. Prepared for legs. 2 filters.	2	850	40118982

FlexFilter EX

	[accessory]	[partno]
	Deflector 220x540	40376771
	Legs Twin Extra High	40375242
	Legs Twin High	40375243
	Legs Single Extra High	40375244
	Legs Single High	40375245
	Service platform for FF EX TWIN	40375246
	Service platform for FF. EX Single	40375247
	Ladder for Service platform FF EX	40375248
	Connection kit for Serv. pltf FF EX	40375249
	Twin RF Kit	40375259
	Flanged pipe d150, 0,5m	40376525*
	Flanged pipe Ø 150, 1 m	40375263*
	Flanged pipe dia 200mm, length 0,5m	40376516
	Flanged bend 45° Ø 150	40376770*
	Flanged bend 90° Ø 150	40375264*
	BigBag PP Type C, 25 pcs	40375271
	Diff.pressure switch 3-15 kPa NC	40375273
	Bin Level Indicator (BLI) EX	40375269
	Fire alarm complete.	40116540
	Replacement plastic Bag 730x900, 20pcs, in conductive material for EX applications	40118800
	Flanged trans.pipe0,2m DN200 B-Flap	40376974
	Flexfilter RBU/VAC - Insight Perform	60200001

FlexFilter EX

[accessory]		[partno]
	Adapter flange/flange DN200 B-Flap	40376977
	Flexfilter RBU/VAC- Insight Perform Plus	60200002

**Pressure resistant pipes and bends for installation between filter inlet and the isolation valve. An adapter is needed between the pipe and isolation valve flanges. Fasteners and seals are included.*

FlexFilter EX

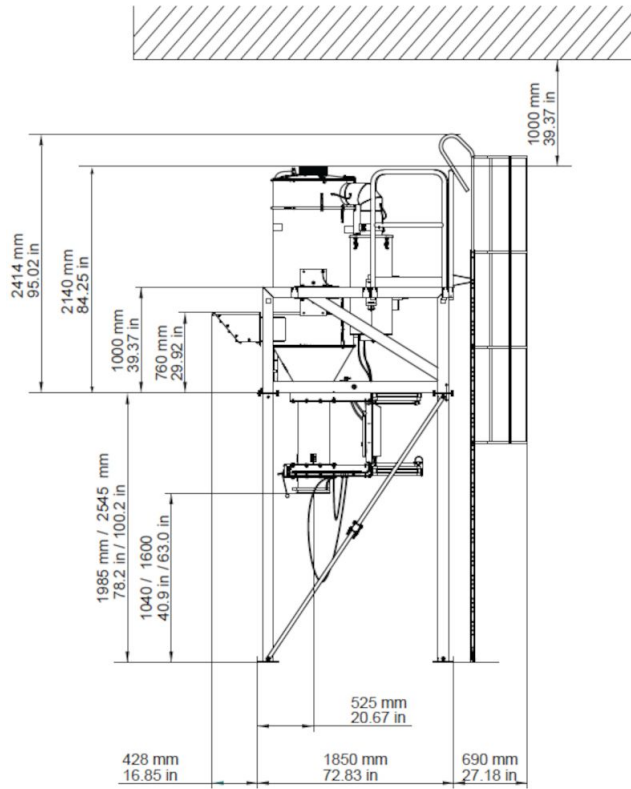

FlexFilter Single & Twin High Stand

FlexFilter EX

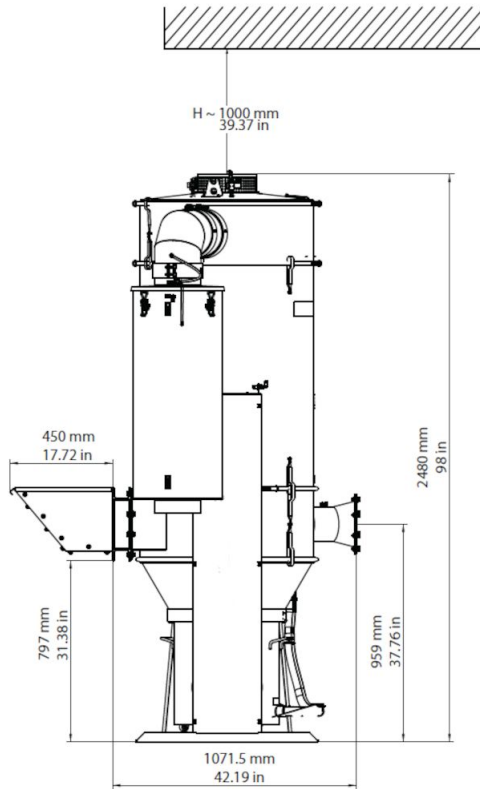

FlexFilter Single & Twin Low Stand

FlexFilter EX

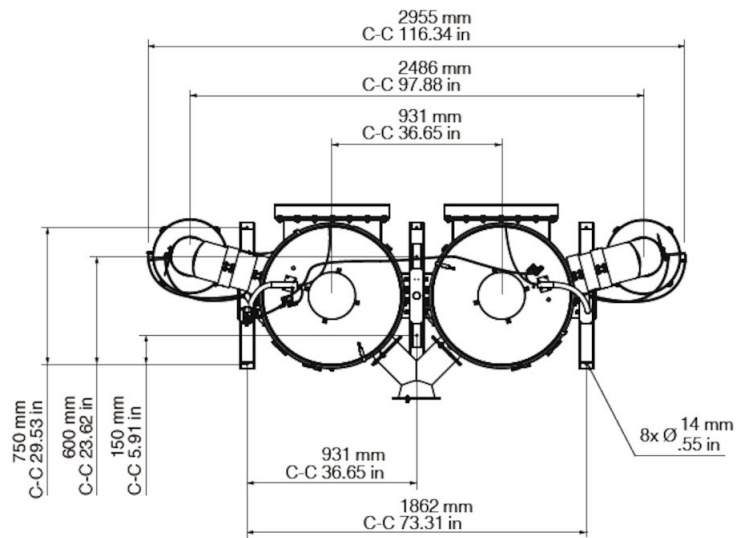

FlexFilter Twin Low Stand

FlexFilter EX

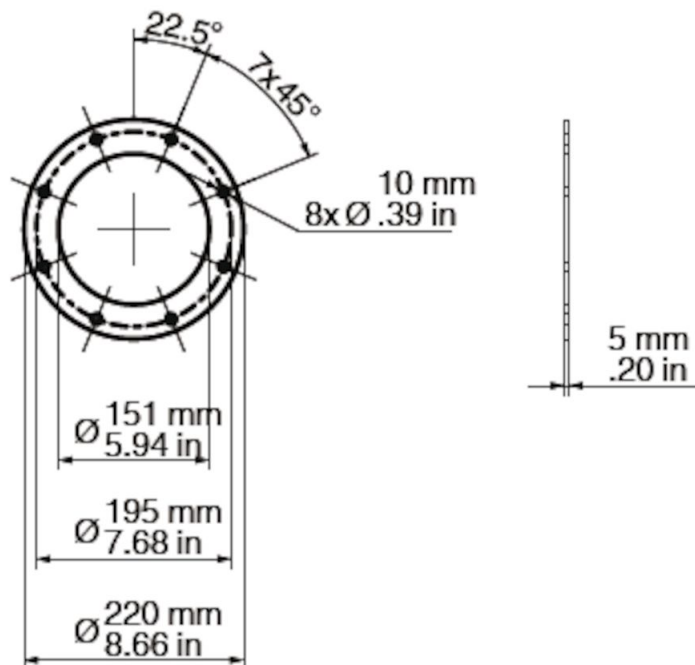

FlexFilter Inlet Single Low & High Stand

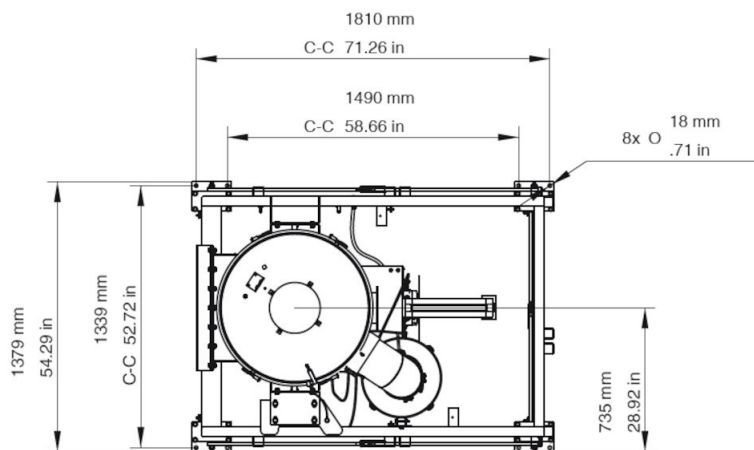

FlexFilter Single High Stand

FlexFilter EX

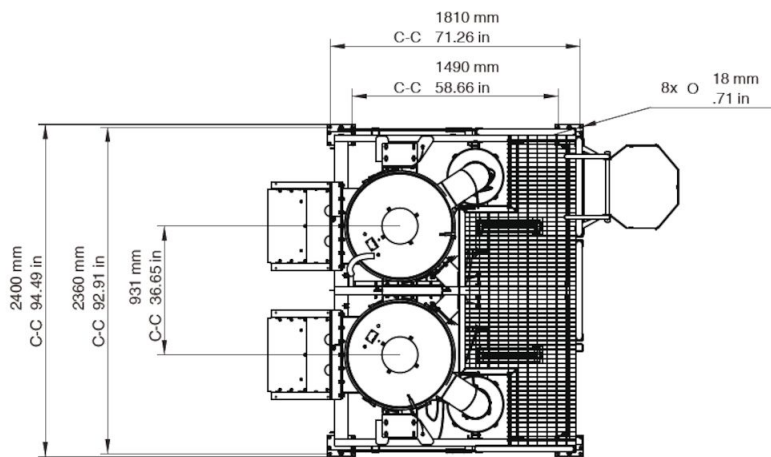

FlexFilter Twin High Stand

FlexFilter EX

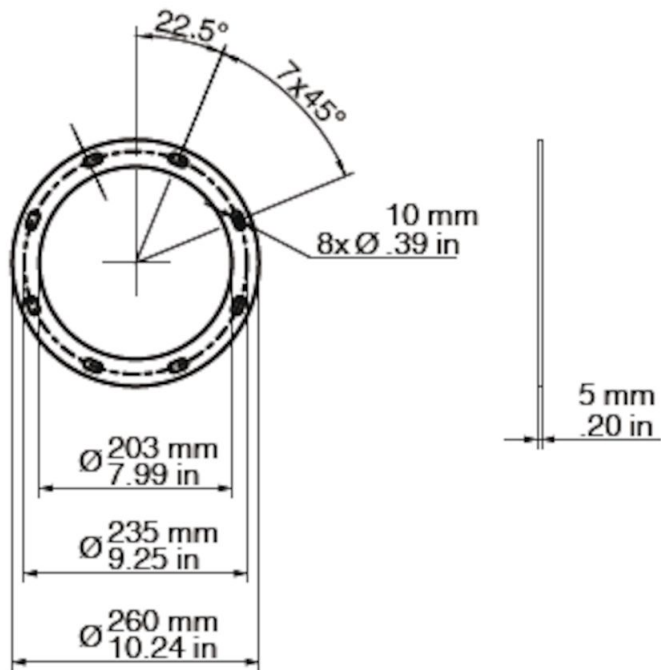

FlexFilter Inlet Twin Low & High Stand

FlexFilter EX

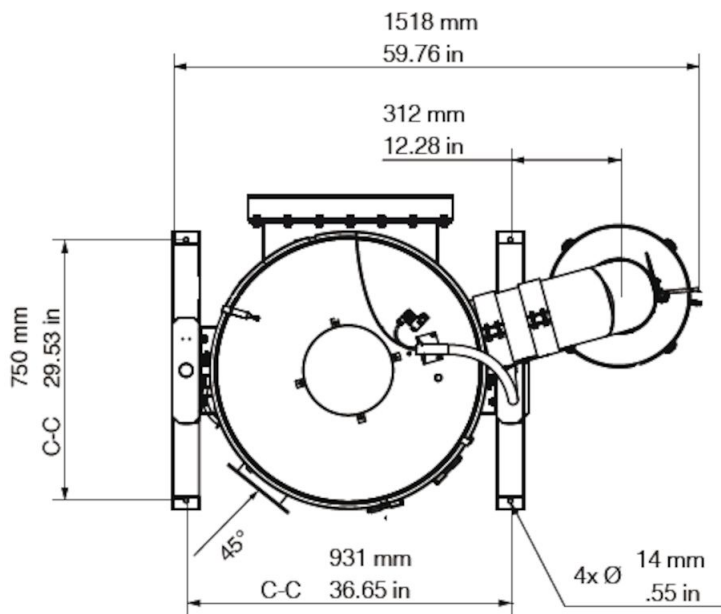

FlexFilter Single Low Stand