

Pre-separation silo for dust collection

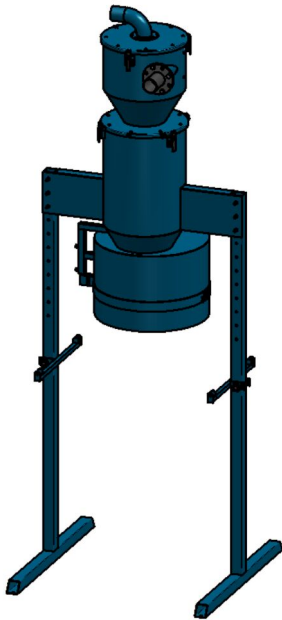

Pre-separator for collecting and recycling of light material as dust, powder and other fine dry materials. Suitable for chemical industry and building and construction industry. The pre-separator can be used with medium to big sized extraction units like RBU` s. The T-leg frame has space for a euro pallet between the legs for forklift handling. It contains a silo S200 with pneumatic opening, in combination with a big-bag holder. This ensure that the discharge of collected material become dustfree. S200 cyclone that takes ou 90-97% of the vacuumed material, depending on the conditions and material. The standard inlet and outlet is Ø102 (4 in).

In most vacuum collection and transport systems a pre-separation of the collected material, before the material reaches the filter is very important. To avoid clogging in the extraction unit using a preseparator is fundamental.

Product naam	Pre-separation silo for dust collection
Further technical data	Inlet/Outlet Ø102 mm

Pre-separation silo for dust collection

Afbeelding	Model
	42962100

Pre-separation silo for dust collection

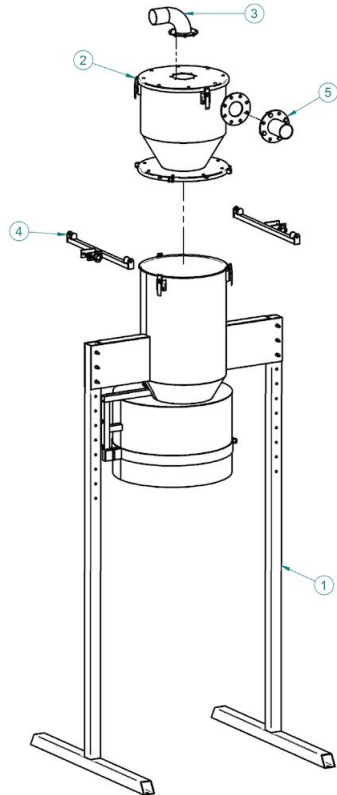

1. Silo 200 T-legs d320: 43452041
2. Cyclone separator S200: 43530001
3. Suction outlet with flange d102: 43620300
4. Bagholder for big bag: 43640209
5. Suction inlet d102 with flange: 43882202