

## OSF 1000 FC

FibreDrain® oil smoke collector for continuous operation.



Nederman OSF oil smoke eliminators are designed to handle large amounts of neat oil mist during continuous operation. They are developed with focus on high efficient filtration together with low maintenance cost.



Nederman OSF 1000 FC has as standard 3 filter-stages where the first 2 stages consists of filter cassettes with Nederman's FibreDrain® technology. Nederman have a wide range of different types of filters to suit many different kind of applications. The third stage consists of a HEPA filter in filter class H13 with an efficiency of 99,95% for MPPS according to EN1822. OSF 1000 FC have an built-in radial fan.

- Three filter stages
- Gauges for reading of pressure drop over each filter stage
- Compact design
- Two inlet  $\varnothing$  200 mm with clamp ring connection
- Starter and motor protection included











Product name	OSF 1000 FC
Standard	2009/125/EC
Volume (for shipping) (m <sup>3</sup> )	1.72
Noise level (dB(A))	50 Hz: 65 dB(A) @1,5 m from service side 60 Hz: 67 dB(A) @1,5 m from service side
Protection class	IP55
Filter efficiency (%)	99,95
Installation	[Indoor]
Material	Sheet metal, painted both in- and outside.
Filter cleaning method	Self-Draining
Working pressure (kPa)	Max 2500 Pa
Capacity (max airflow m <sup>3</sup> /h)	1000
Operating Temperature	40 deg C (inbuilt fan)
Power Voltage (V)	230/400
Frequency (Hz)	50
No of phases	3
Number of filter elements	3
Amperage (A)	4,2 / 2,4
Colour	NCS-S 1005 B20G
Weight (kg)	200
Power (kW)	1,1
Note	



## OSF 1000 FC

Image	Description	Model
	OSF 1000 FC, Inlet Right or Back ø 200 mm clamp ring. Drain 1" Female	12400005
	OSF 1000 FC, Inlet Left or Back ø 200 mm clamp ring. Drain 1" Female	12400196

## OSF 1000 FC

	Accessory	Part No
	Drain pump box, 50 Hz	12400054*
	Drain container with piping	12400764**
	FibreDrain Filter 1 OSF; 600x600x292 mm	12400006
	FibreDrain Filter 2 OSF; 600x600x292 mm	12400007
	HEPA Filter H13; 610x610x150 mm	12400852
	High capacity HEPA-filter kit for FC	12400984
	Outlet connection OSF 1000FC / OMF 2000FC - HEPA 610x610x292mm	12400726
	Outlet connection OSF 1000FC / OMF 2000FC - HEPA 610x610x150mm	12400959
	Drain pump box, 50 Hz, 10 litre/min at 10m, including controller	12401330
	Frequency inverter with 2 kPa pressure sensor. 1,5kW	73008913

\*Drain connection must be elevated min 200 mm from pump box support level

\*\*Drain connection must be elevated min 420mm from container support level

## OSF 1000 FC

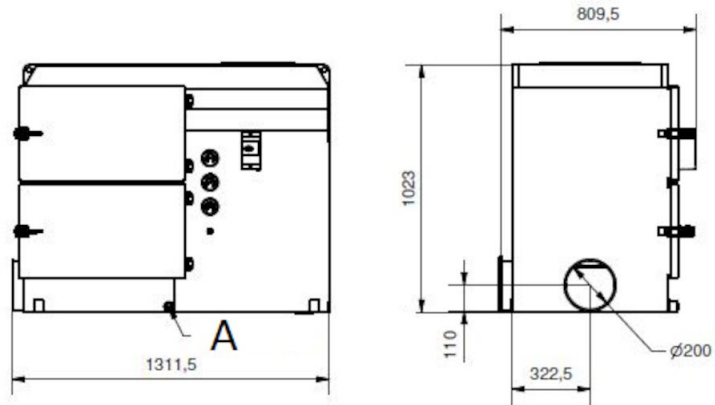

A) Drain stud (x2)

Dimensions for outlet connection:

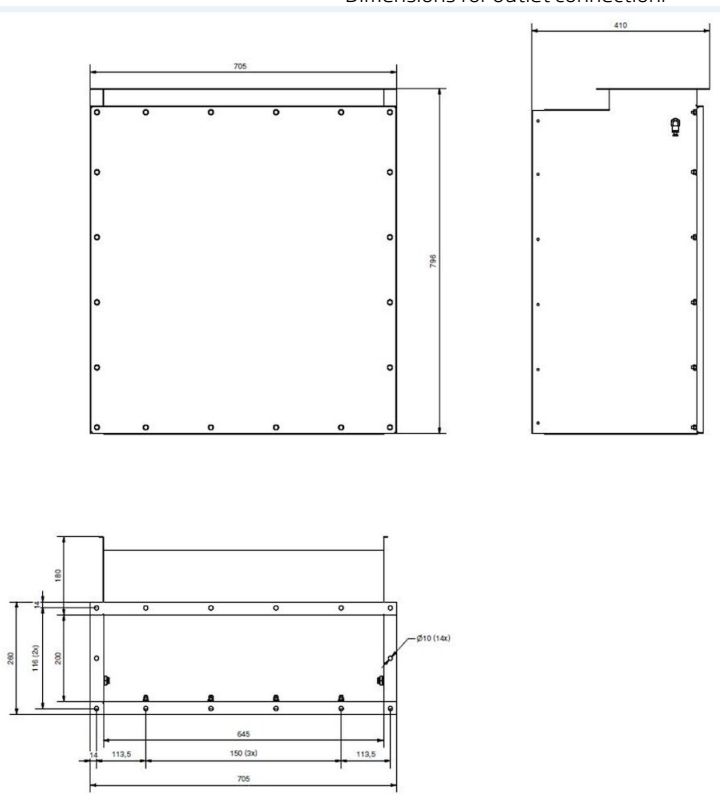

## OSF 1000 FC

Dimensions for outlet connection:

