

## Exhaust Hose Reel 865 - Spring Recoiled

### Spring Recoiled Exhaust Hose Reel

---



For all types of vehicle workshops, etc. where the hose can hang at a reachable height. The patented spring drive makes the reel very easy to handle. The reel is available with or without automatic damper, the one with a patented integrated automatic damper saves energy and reduces the noise level. Optional retraction control is available for increased safety and efficiency. Two separate suspension brackets make mounting the reel a simple and safe procedure. The brackets are fixed to the wall or ceiling before the light-weight reel is lifted directly on to the brackets. It is possible to mount the fan directly on the reel.

- Easy, balanced operation
- Quick & easy installation reduces cost
- Automatic fan for energy savings
- Easy adjustment of lifting capacity
- Compact, modern design



Product name	Exhaust Hose Reel 865 - Spring Recoiled
Electric/Spring driven	Spring



## Exhaust Hose Reel 865 - Spring Recoiled

[Image]	Type of hose *	Delivered with hose	Colour	Body type	Diameter, hose (mm)	Hose length (m)	Weight (kg)	Max hose length	[model]
	NTP		Blue		125	7,5	41-49	10	20801765*
	NTP		Blue		75	5	31-38	7,5	20800865*
	NR-CP		Blue		75	5	31-38	7,5	20801465
	Without		Blue		75		23	7,5	20800965
	NTP		Blue		100	5	31-38	7,5	20810265*
	NR-CP		Blue		100	5	31-38	7,5	20800665
	NTP		Blue		100	7,5	41-49	10	20810365*
	NR-CP		Blue		100	7,5	31-38	7,5	20805365**
	NTP		Blue		100	10	41-49	10	20811265*
	NR-CP		Blue		100	10	41-49	10	20801965
	Without		Blue		100		23	7,5	20800765
	Without		Blue		100		31	10	20800365
	NTP		Blue		125	5	31-38	5	20800465
	NR-CP		Blue		125	5	31-38	5	20801165
	NR-CP		Blue		125	7,5	41-49	10	20802065

## Exhaust Hose Reel 865 - Spring Recoiled

[Image]	Type of hose <sup>1</sup>	Delivered with hose	Colour	Body type	Diameter, hose (mm)	Hose length (m)	Weight (kg)	Max hose length	[model]
	NR-CP		Blue		125	10	41-49	10	20802165
	Without		Blue		125		31	10	20800165
	NR-CP		Blue		150	5	31-38	5	20801065
	NR-CP		Blue		150	7,5	41-49	10	20802265**
	NR-CP		Blue		150	10	41-49	10	20802365**
	Without		Blue		150		31	10	20804265
	Without		Blue		150		23	5	20804165
	Without		Blue		200		31	7	20809065*
	Without		Grey		100		23	7,5	20809365
	NR-CP		Grey		150	10	31-38		20810465
	NR-CP		Grey		100	7,5	41-49		20811365

\*Without damper

\*\*Reinforced spring

<sup>1</sup> See table below

Hose type	Specification	Temperature range, °C	Hose fittings in free hose end, distribution hose	Hose fitting on free hose end, inlet hose	Hose connection on reel, distribution hose	Hose connection on reel, inlet hose
NTP		up to 150				
NRCP		-40 to +150 Deg. C (Intermittent +170 Deg. C)				

## Exhaust Hose Reel 865 - Spring Recoiled

	[accessory]	[partno]
	Exhaust hose nr-cp l=5m d=102mm	20807962
	Exhaust hose nr-cp l=10m d=102mm	20808162
	Exhaust hose nr-cp l=5m d=127mm	20808362
	Exhaust hose nr-cp l=5m d=152mm	20808762
	Exhaust hose nr-cp l=10m d=152mm	20808962
	Exhaust hose nr-cp l=2.5m d=100mm	20820362
	Exhaust hose nr-cp l=5m d=100mm	20820462
	Exhaust hose nr-cp l=7.5m d=100mm	20820562
	Exhaust hose nr-cp l=10m d=100mm	20820662
	Exhaust hose nr-cp l=2.5m d=125mm	20820762
	Exhaust hose nr-cp l=5m d=125mm	20820862
	Exhaust hose nr-cp l=7.5m d=125mm	20820962
	Exhaust hose nr-cp l=10m d=125mm	20821062
	Exhaust hose nr-cp l=2.5m d=150mm	20821162
	Exhaust hose nr-cp l=5m d=150mm	20821262
	Exhaust hose nr-cp l=7.5m d=150mm	20821362
	Exhaust hose nr-cp l=10m d=150mm	20821462
	865 Controlled retraction kit	20373880
	Extraction trolley Reel on rail	20948610
	On-off switch	20373557
	Stand for fan	20373556
	Transformer 230/250 V to 24 V. 75 VA.	10361560

## Exhaust Hose Reel 865 - Spring Recoiled

	[accessory]	[partno]
	Transformer 230/250V to 24V, 25 VA	10363189
	Rebuilding kit for double springs	20374111
	Exhaust Reel Spring, without damper	20809065*

\*Without damper

## Exhaust Hose Reel 865 - Spring Recoiled

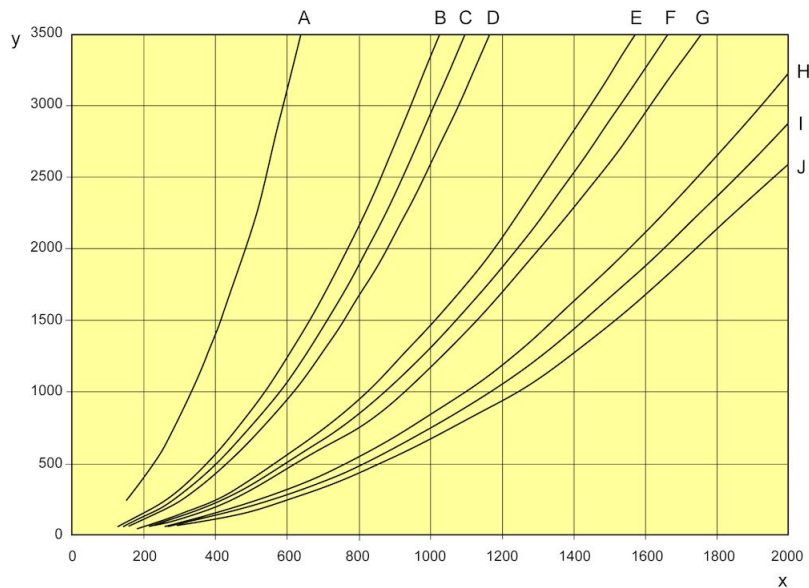

A. 75 mm (3"), 5 m (16'), B. 100 mm (4"), 10 m (33'), C. 100 mm (4"), 7.5 m (25'), D. 100 mm (4"), 5 m (16'), E. 125 mm (5"), 10 m (33'), F. 125 mm (5"), 7.5 m (25'), G. 125 mm (5"), 5 m (16'), H. 150 mm (6"), 10 m (33'), I. 150 mm (6"), 7.5 m (25'), J. 150 mm (6"), 5 m (16')

For exhaust extraction systems in vehicle repair shops where engines are running without load and with low rpm's, the following air flows can be used as guidelines: Cars = 400 m<sup>3</sup>/h (110 l/s; 250 cfm) Trucks = 1000 m<sup>3</sup>/h (280 l/s; 600 cfm) (pressure drop over reel when most of the hose is uncoiled)

X = m<sup>3</sup>/h

Y = Pressure drop, (Pa)

## Exhaust Hose Reel 865 - Spring Recoiled

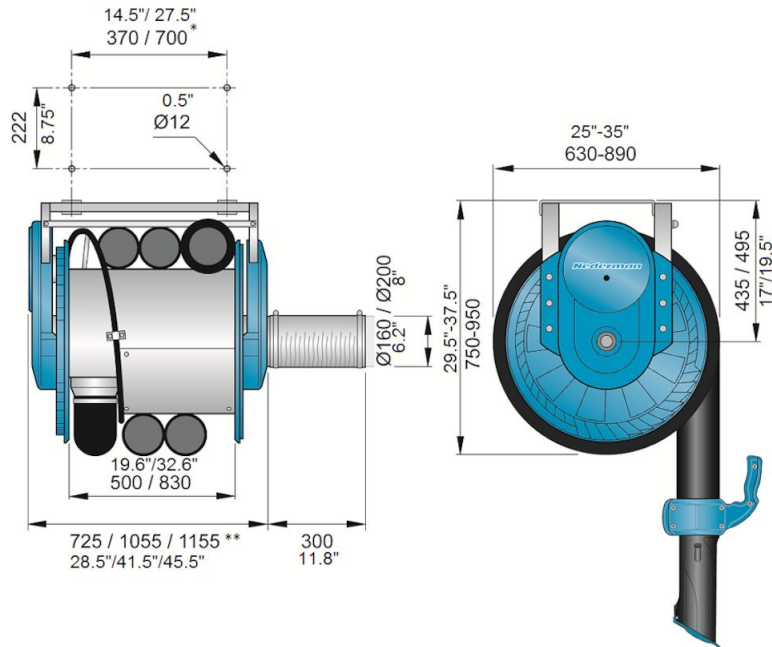

\*) short drum / wide drum

\*\*\*) short drum / wide drum 100 - 150mm/ wide drum 200mm