

Exhaust Hose Reel 865 - Spring Recoiled

Spring Recoiled Exhaust Hose Reel



For all types of vehicle workshops, etc. where the hose can hang at a reachable height. The patented spring drive makes the reel very easy to handle. The reel is available with or without automatic damper, the one with a patented integrated automatic damper saves energy and reduces the noise level. Optional retraction control is available for increased safety and efficiency. Two separate suspension brackets make mounting the reel a simple and safe procedure. The brackets are fixed to the wall or ceiling before the light-weight reel is lifted directly on to the brackets. It is possible to mount the fan directly on the reel.

- Easy, balanced operation
- Quick & easy installation reduces cost
- Automatic fan for energy savings
- Easy adjustment of lifting capacity
- Compact, modern design



Product name	Exhaust Hose Reel 865 - Spring Recoiled
Corrosion resistance	Standard
Electric/Spring driven	Spring



Exhaust Hose Reel 865 - Spring Recoiled

Image	Type of hose ¹	Delivered with hose	Colour	Body type	Diameter, hose (mm)	Hose length (m)	Weight (kg)	Max hose length	Model
	NTP	Yes	Blue	Wide body	125	7,5	41-49	10	20801765*
	NTP	Yes	Blue	Short body	75	5	31-38	7,5	20800865*
	NR-CP	Yes	Blue	Short body	75	5	31-38	7,5	20801465
	Without	No	Blue	Short body	75		23	7,5	20800965
	NTP	Yes	Blue	Short body	100	5	31-38	7,5	20810265*
	NR-CP	Yes	Blue	Short body	100	5	31-38	7,5	20800665
	NTP	Yes	Blue	Wide body	100	7,5	41-49	10	20810365*
	NR-CP	Yes	Blue	Short body	100	7,5	31-38	7,5	20805365**
	NTP	Yes	Blue	Wide body	100	10	41-49	10	20811265*
	NR-CP	Yes	Blue	Wide body	100	10	41-49	10	20801965
	Without	No	Blue	Short body	100		23	7,5	20800765
	Without	No	Blue	Wide body	100		31	10	20800365
	NTP	Yes	Blue	Short body	125	5	31-38	5	20800465*
	NR-CP	Yes	Blue	Short body	125	5	31-38	5	20801165
	NR-CP	Yes	Blue	Wide body	125	7,5	41-49	10	20802065

Exhaust Hose Reel 865 - Spring Recoiled

Image	Type of hose ¹	Delivered with hose	Colour	Body type	Diameter, hose (mm)	Hose length (m)	Weight (kg)	Max hose length	Model
	NR-CP	Yes	Blue	Wide body	125	10	41-49	10	20802165
	Without	No	Blue	Wide body	125		31	10	20800165
	NR-CP	Yes	Blue	Short body	150	5	31-38	5	20801065
	NR-CP	Yes	Blue	Wide body	150	7,5	41-49	10	20802265**
	NR-CP	Yes	Blue	Wide body	150	10	41-49	10	20802365**
	Without	No	Blue	Wide body	150		31	10	20804265
	Without	No	Blue	Short body	150		23	5	20804165
	Without	No	Blue	Wide body	200		31	7	20809065*
	Without	No	Grey	Short body	100		23	7,5	20809365
	NR-CP		Grey	Wide body	150	10	31-38		20810465
	NR-CP	Yes	Grey	Short body	100	7,5	41-49		20811365
	NFC-3	Yes	Grey	Wide body	150	7,5			20811765

*Without damper

**Reinforced spring

¹ See table below

Hose type	Specification	Temperature range, °C	Hose fittings in free hose end, distribution hose	Hose fitting on free hose end, inlet hose	Hose connection on reel, distribution hose	Hose connection on reel, inlet hose
NTP	Theromplastic polyester fabric coated with EPDM/PP. Bending radius 244mm.	up to 150				

Exhaust Hose Reel 865 - Spring Recoiled

NRCP	Polyester fabric, EPDM/PP coated. Helix in Polyester with EPDM cover. Max bending radius 225mm (inside)	-40 to +150 Deg. C (Intermittent +170 Deg. C)				
NFC3	High temperature kevlar based material. Helix in galvanised steel.	-60 to +300 Deg. C (Intermittent +350 Deg. C)				

Exhaust Hose Reel 865 - Spring Recoiled

	Accessory	Part No
	865 Controlled retraction kit	20373880
	Extraction trolley Reel on rail	20948610
	On-off switch	20373557
	Direct mount Stand for fan on 865 Hose Reel	20373556
	Transformer 230/250 V to 24 V. 75 VA.	10361560
	Transformer 230/250V to 24V, 25 VA	10363189
	Rebuilding kit for double springs	20374111
	Nozzle 150 exhaust aluminium EX	20870361
	Nozzle exhaust rubber for hose EX	20870261

Exhaust Hose Reel 865 - Spring Recoiled

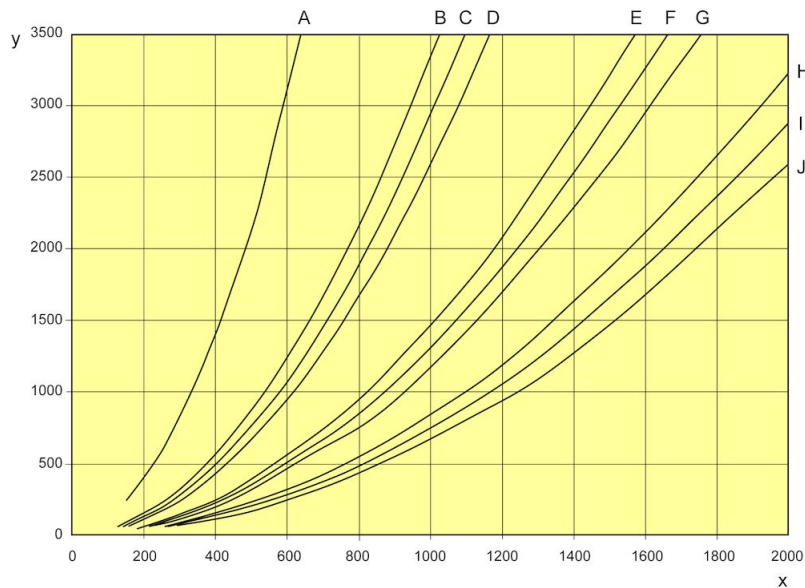

A. 75 mm (3"), 5 m (16'), B. 100 mm (4"), 10 m (33'), C. 100 mm (4"), 7.5 m (25'), D. 100 mm (4"), 5 m (16'), E. 125 mm (5"), 10 m (33'), F. 125 mm (5"), 7.5 m (25'), G. 125 mm (5"), 5 m (16'), H. 150 mm (6"), 10 m (33'), I. 150 mm (6"), 7.5 m (25'), J. 150 mm (6"), 5 m (16')

For exhaust extraction systems in vehicle repair shops where engines are running without load and with low rpm's, the following air flows can be used as guidelines: Cars = 400 m³/h (110 l/s; 250 cfm) Trucks = 1000 m³/h (280 l/s; 600 cfm) (pressure drop over reel when most of the hose is uncoiled)

X = m³/h

Y = Pressure drop, (Pa)

Exhaust Hose Reel 865 - Spring Recoiled

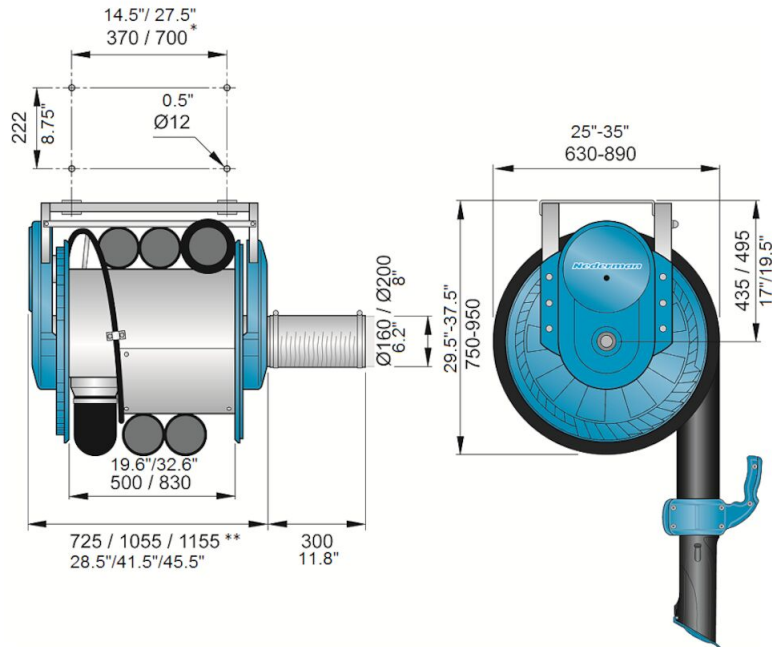

*) short drum / wide drum

***) short drum / wide drum 100 - 150mm/ wide drum 200mm