

Fans and Vacuum Pumps

VAC 20 Vacuum Unit

Bearing Replacement

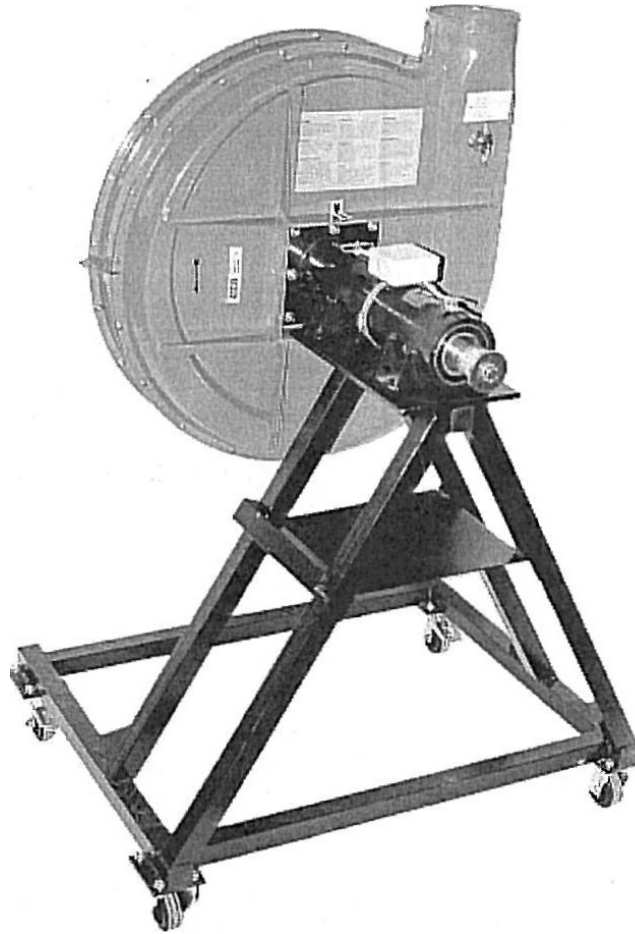

Original Inatallation and service manual

EN INSTALLATION AND SERVICE MANUAL



Figures	4
English	15

Figures

1

①

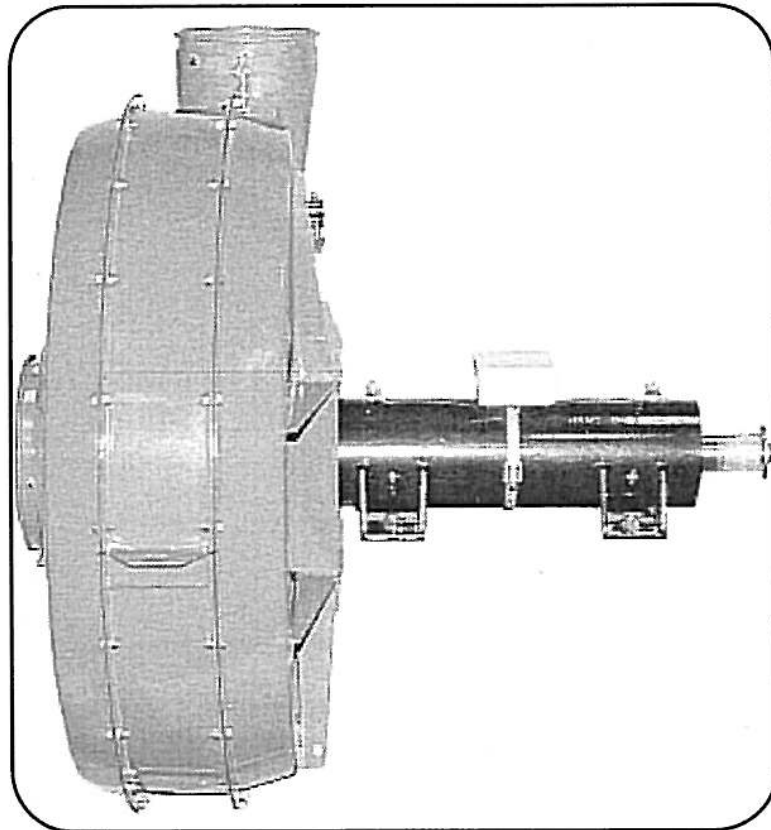

②

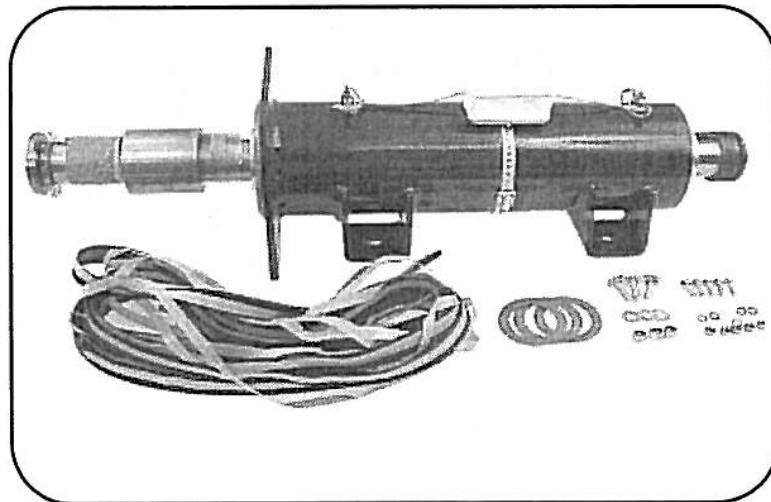

③

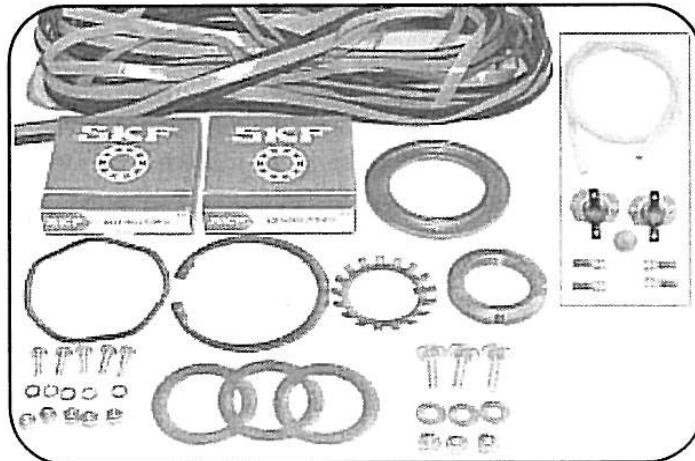

2

1



2

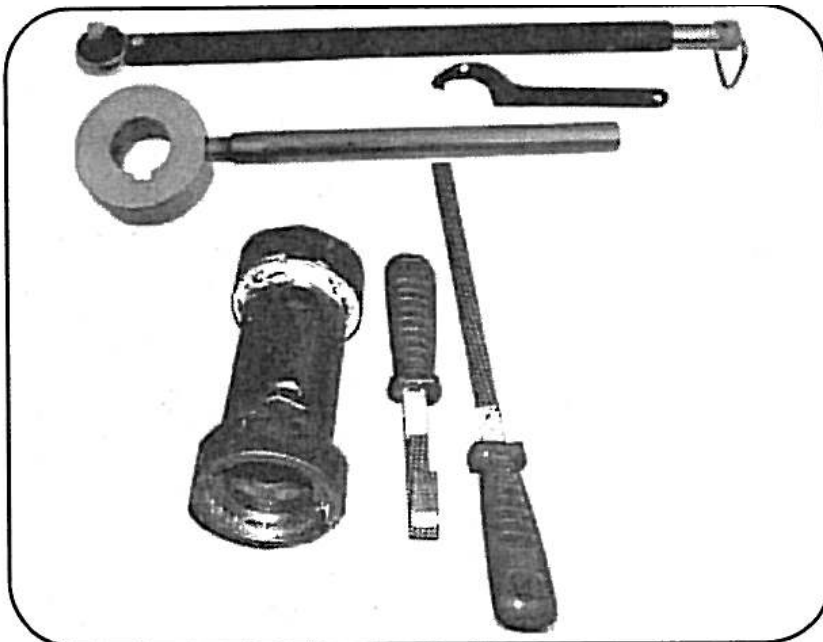

3

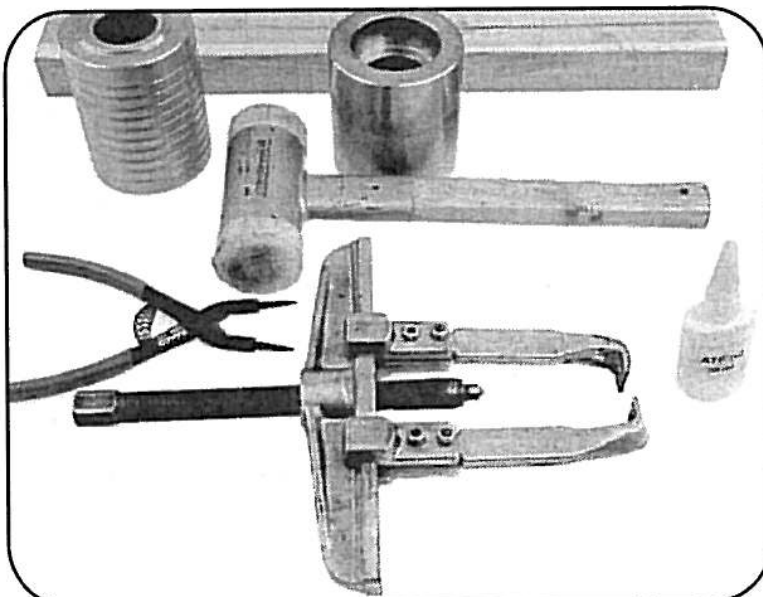

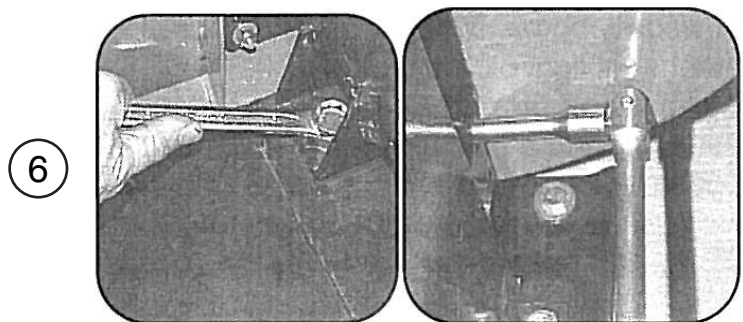
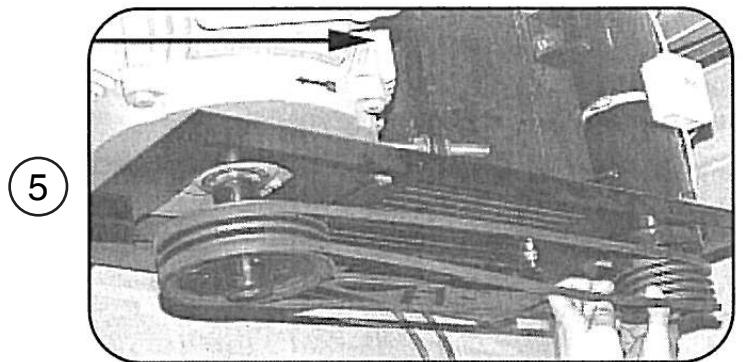
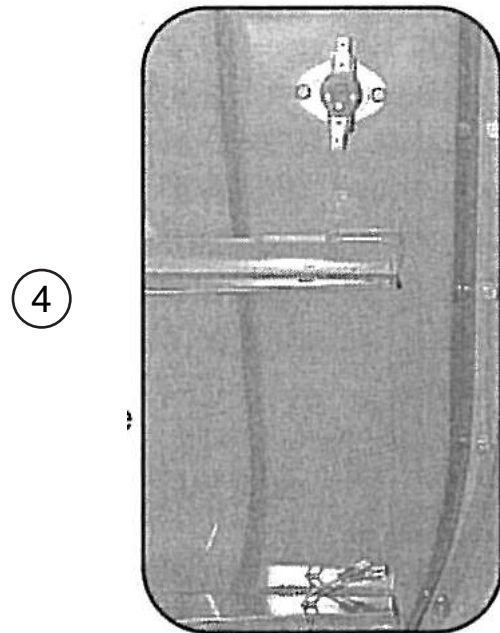
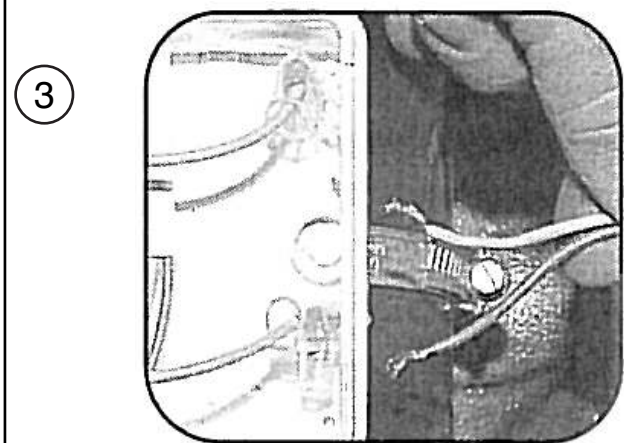
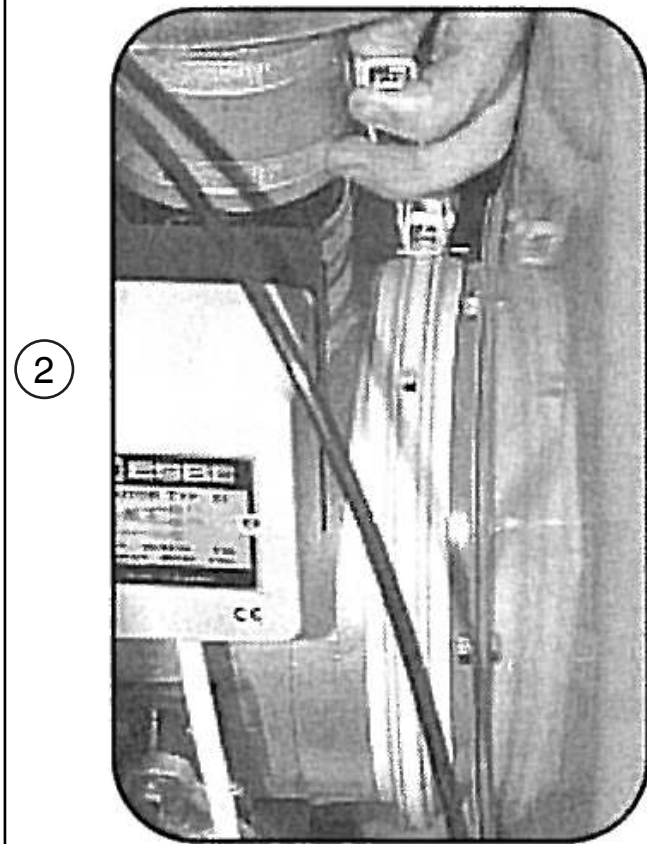
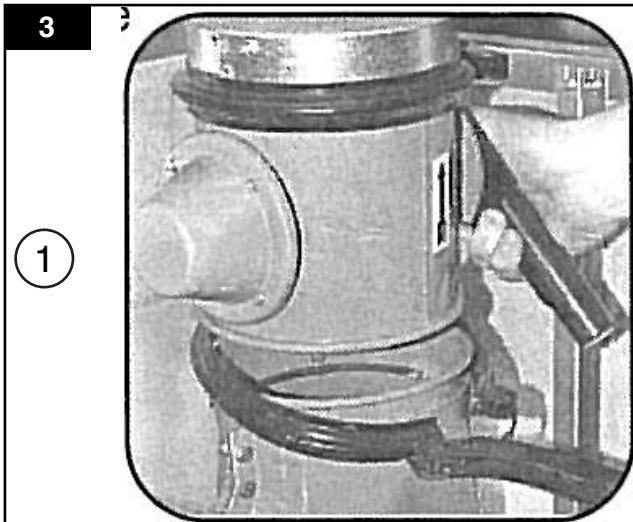

4

1

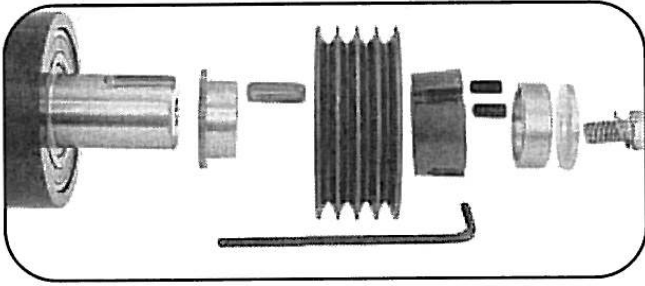

2



3

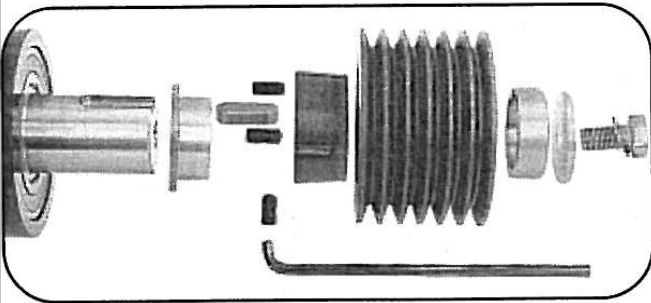

4

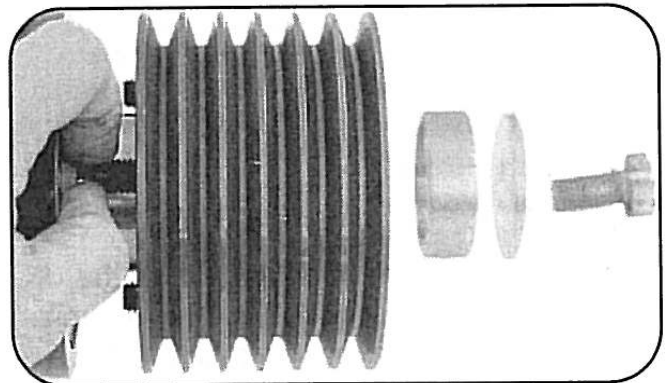

5

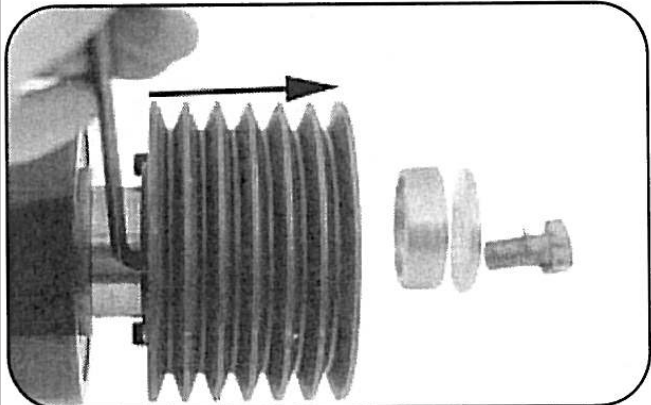

6

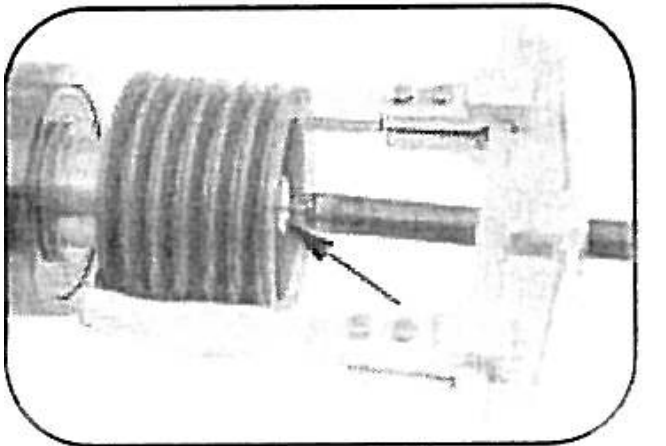

5

1

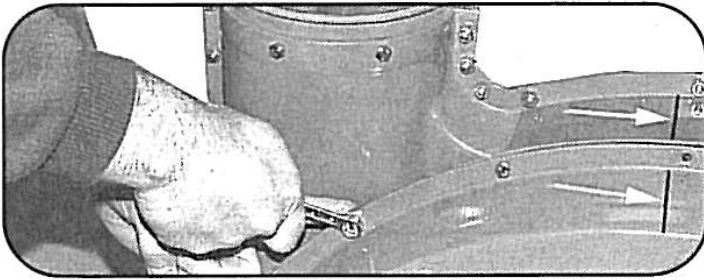

2

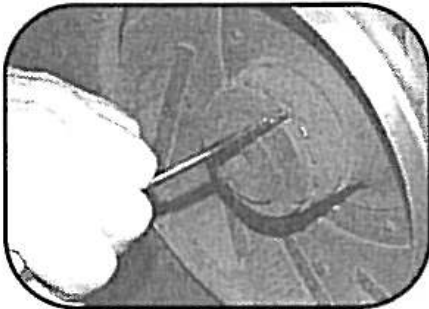

3

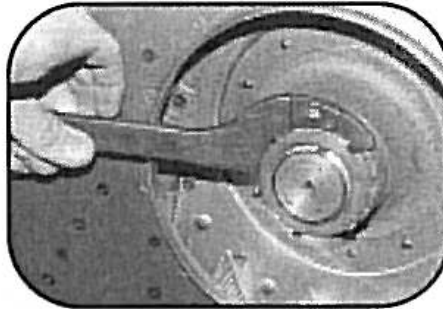

4



5

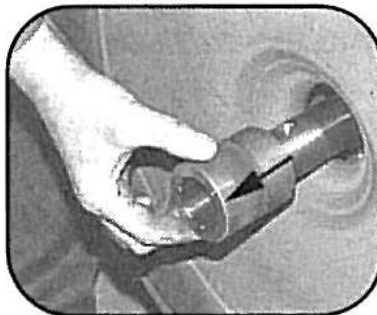

6



7

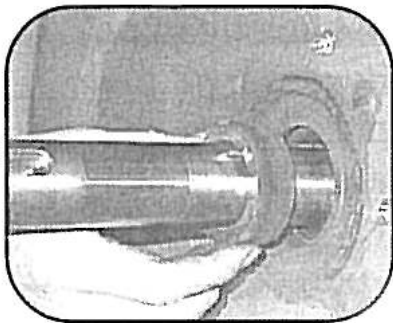

8

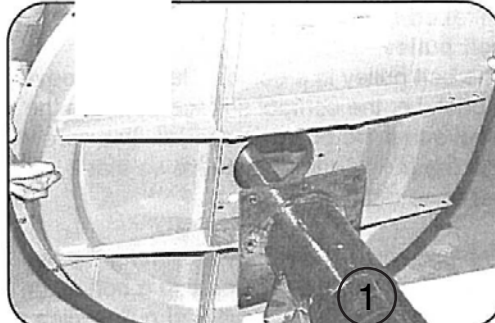

6

1

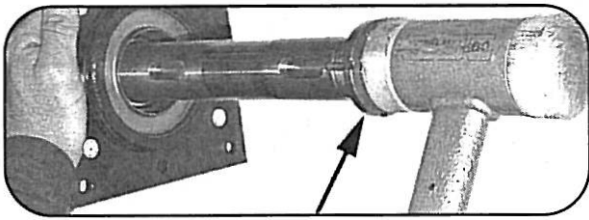

2

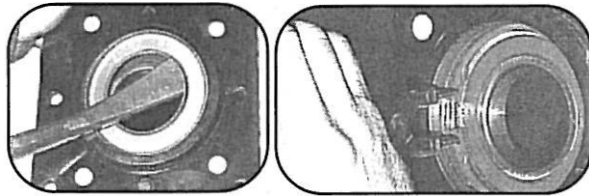

3

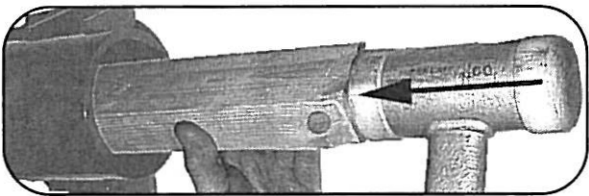

4

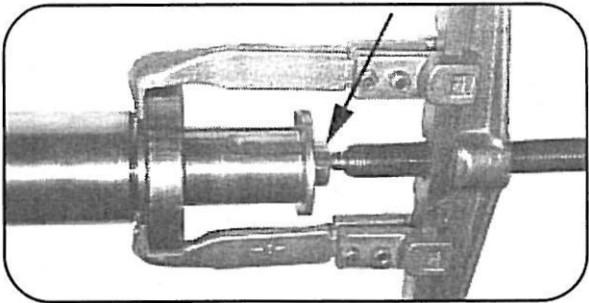

5

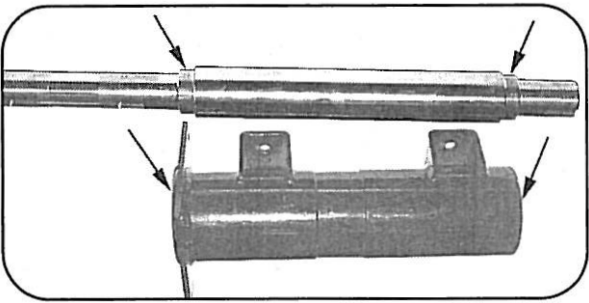

6

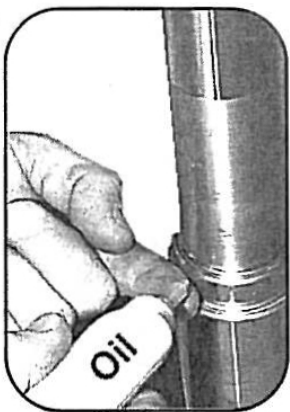

7

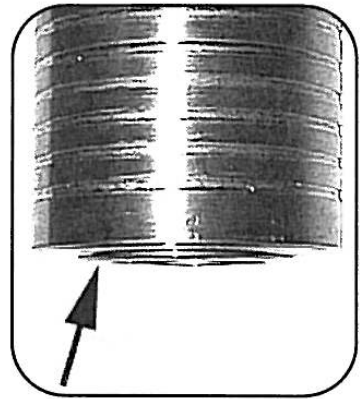

8

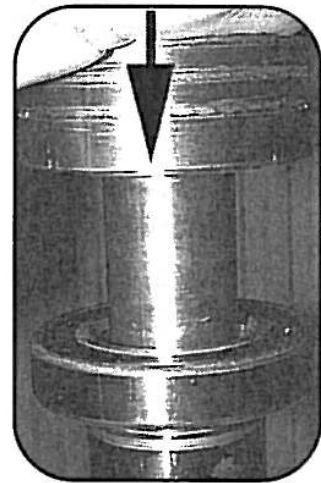

9

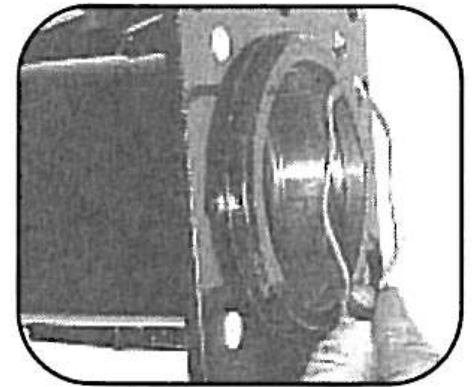

10

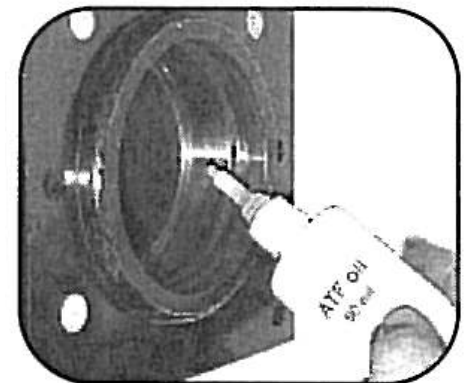

6 continued

11

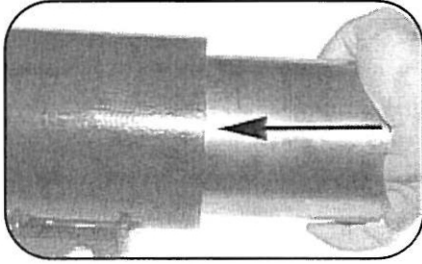

12

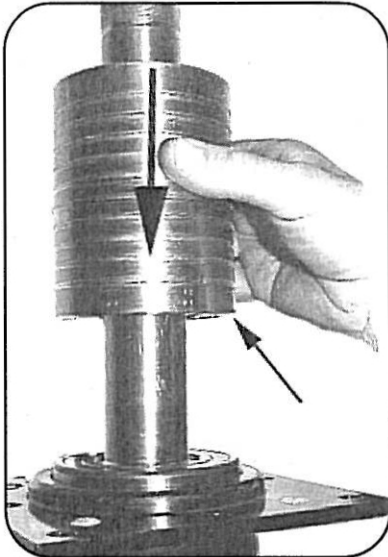

13

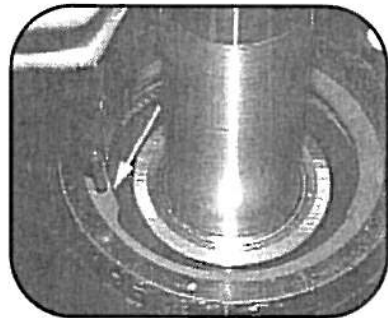

14

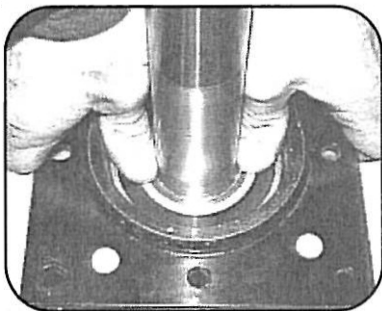

15

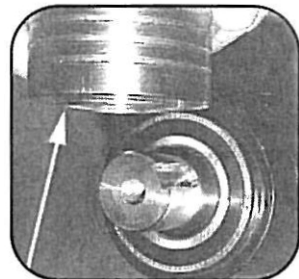

16



17

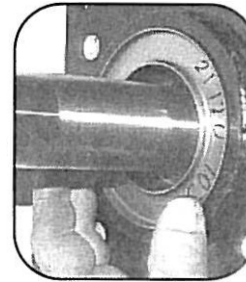

18

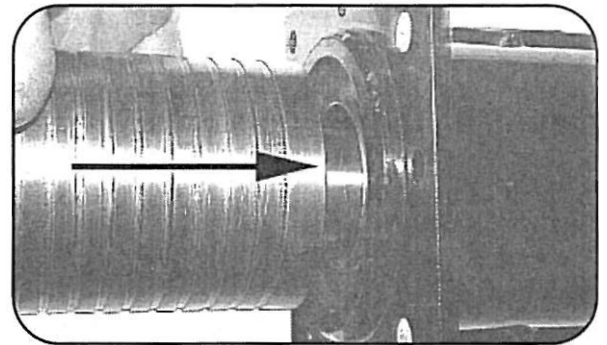

19



7

1

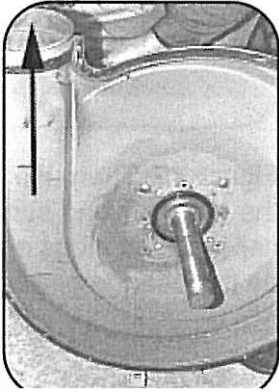

2

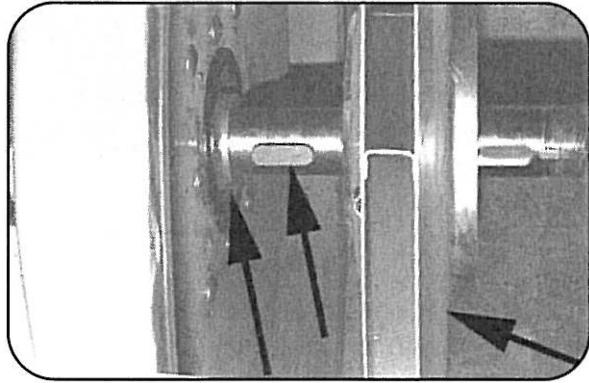

3



4



5



6

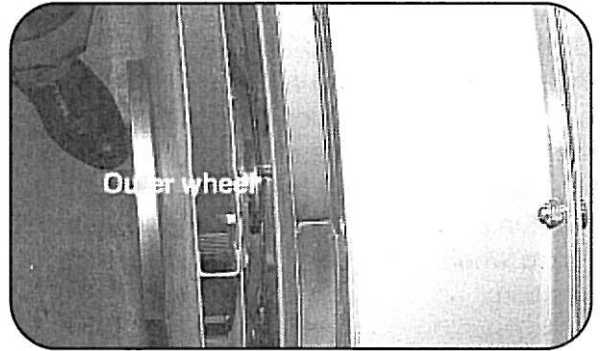

7

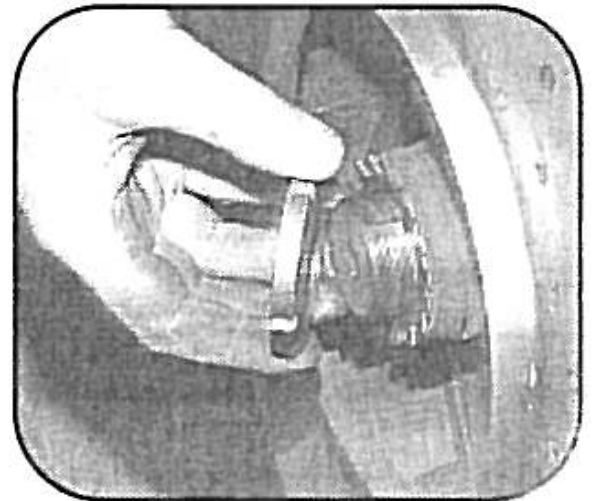

7 continued

8

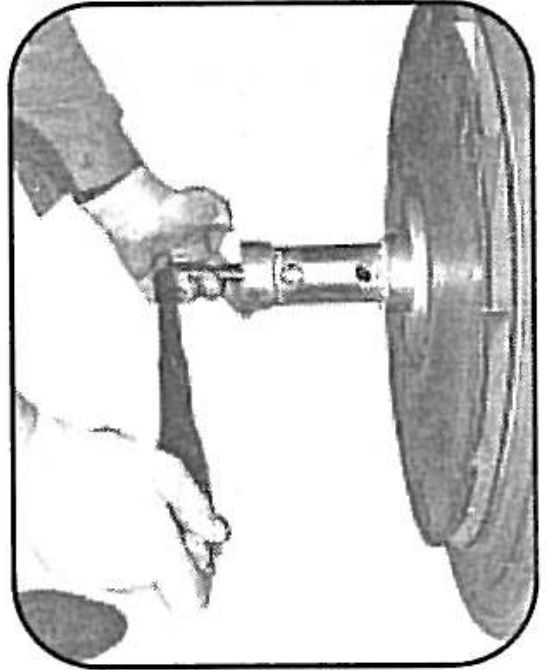
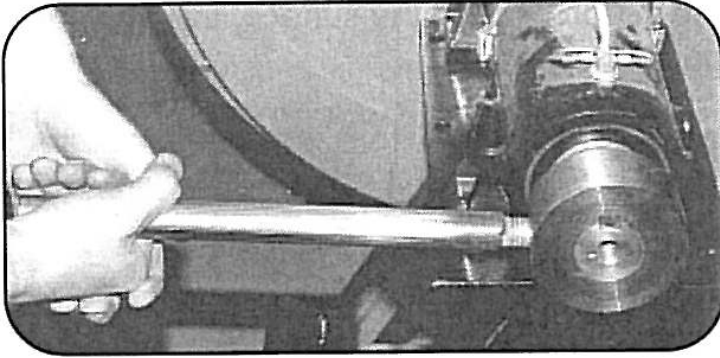

1

9

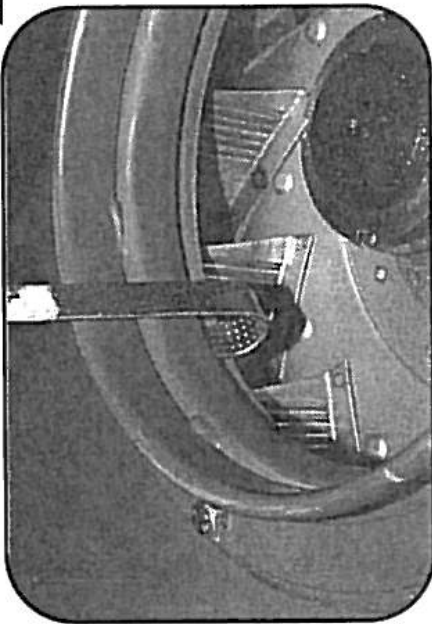

8

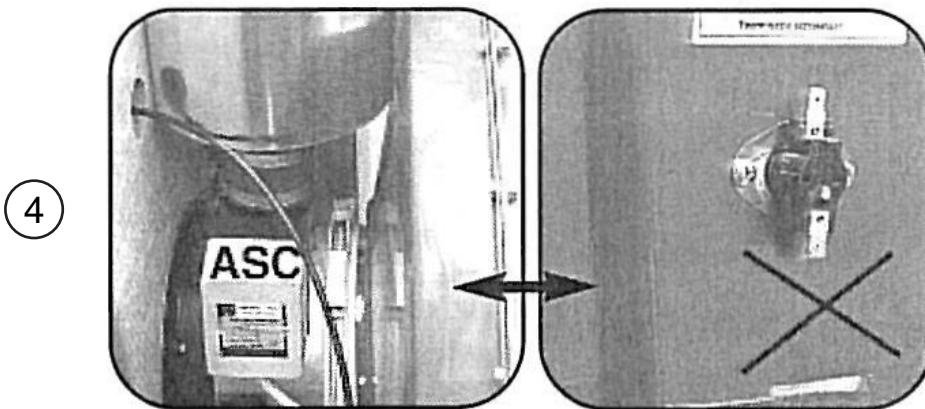
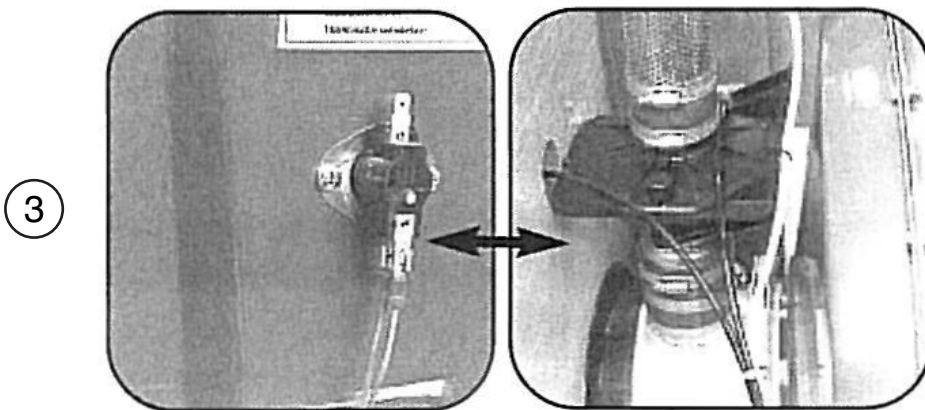
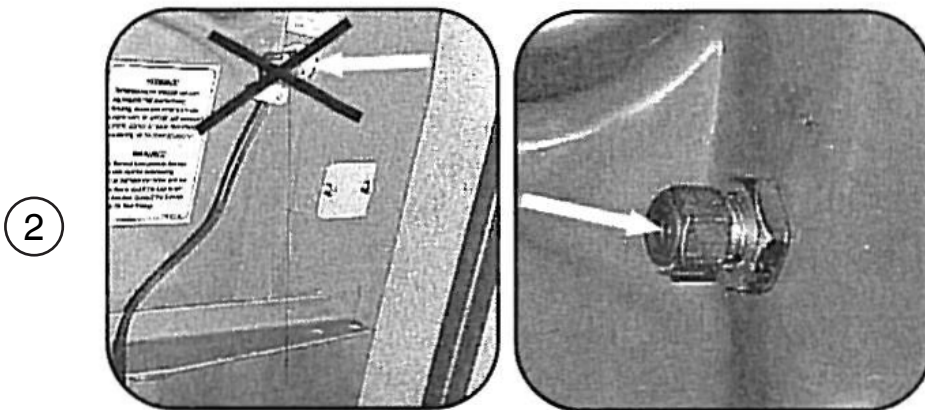
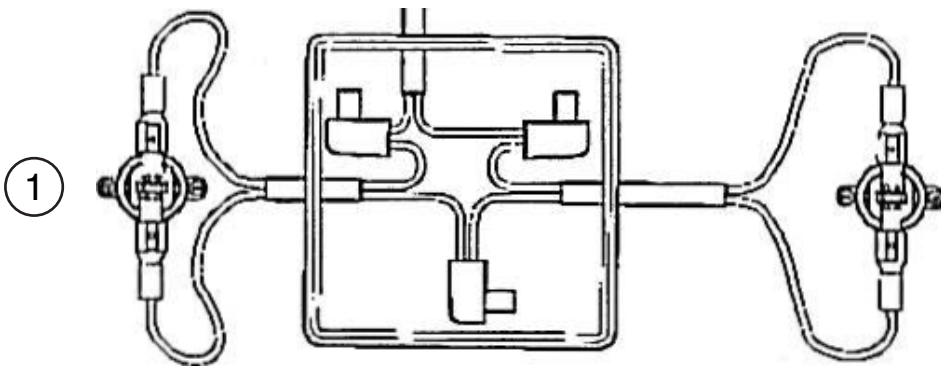

8 continued

5

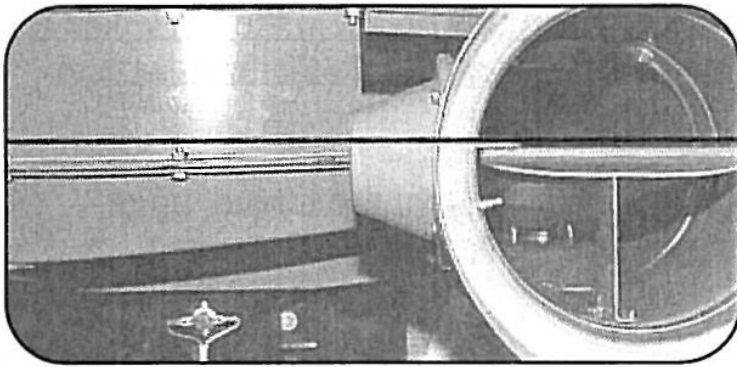

6

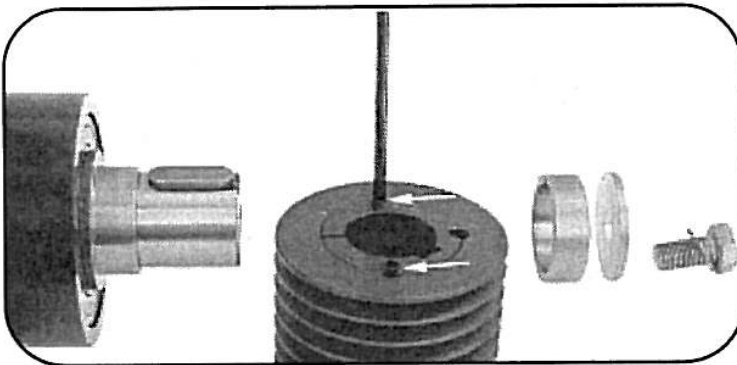

7

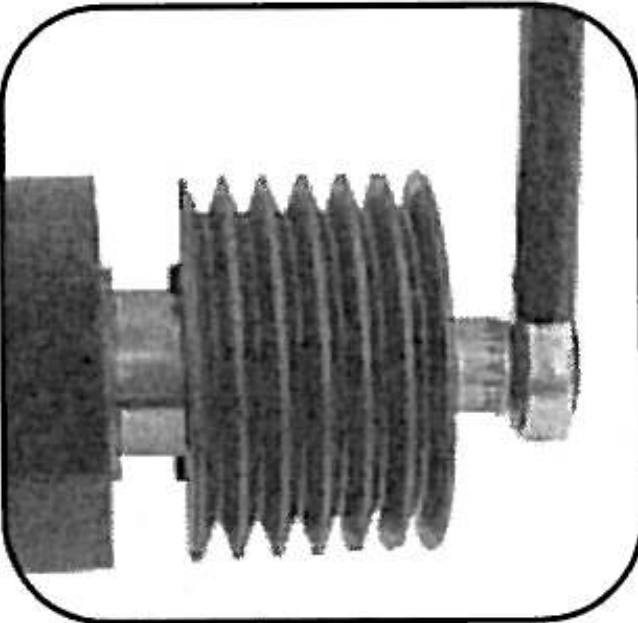

8

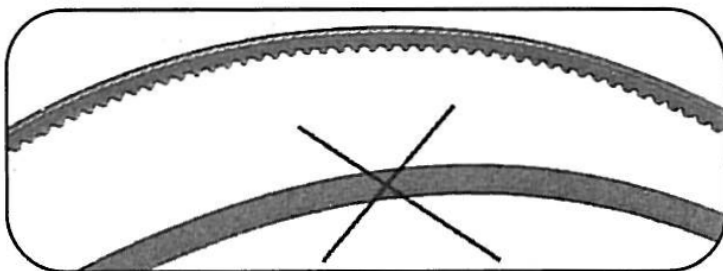

English
Installation and service manual
Bearing replacement

Table of contents

1	Preface.....	16
2	Safety.....	16
3	Bearing replacement.....	16
3.1	Replacement options.....	16
3.2	Replacement tools.....	16
3.2.1	Replacement Option 1.....	17
3.2.2	Replacement Option 2.....	17
3.2.3	Replacement Option 3.....	17
3.3	Other service measures.....	17
3.4	Replacement procedure:.....	17
3.4.1	Dismantle the fan unit from the vacuum pump (Option 1, 2 & 3).....	18
3.4.2	Detailed instructions for removing the belt pulley.....	18
3.4.3	Dismantling the fan (Options 2 & 3).....	19
3.4.4	Replacing the bearing (Option 3).....	19
3.4.5	Fitting the fan and bearing pedestal. (Opt 2 & 3).....	21
3.4.6	Fitting the fan in the vacuum unit (Opt. 1, 2 & 3).....	21
3.4.7	Test running.....	22

1 Preface

Read this manual carefully before installation, use and service of this product. Replace the manual immediately if lost. Nederman reserves the right, without previous notice, to modify and improve its products including documentation.

This product is designed to meet the requirements of relevant EC directives. To maintain this status, all installation, maintenance and repair is to be done by qualified personnel using only Nederman original spare parts and accessories. Contact the nearest authorized distributor or Nederman for advice on technical service and obtaining spare parts. If there are any damaged or missing parts when the product is delivered, notify the carrier and the local Nederman representative immediately.

2 Safety

This document contains important information that is presented either as a warning, caution or note:

 **WARNING! Risk of personal injury.**
Warnings indicate a potential hazard to the health and safety of personnel, and how that hazard may be avoided.

 **CAUTION! Risk of equipment damage.**
Cautions indicate a potential hazard to the product but not to personnel, and how that hazard may be avoided.

 **NOTE!** Notes contain other information that is important for personnel.

3 Bearing replacement

3.1 Replacement options

See figure 1. There are three bearing replacement options.

1. Install the fan unit complete with bearing pedestal. This is the quickest option. It should take 2 to 3 hours if the vacuum unit is positioned so that the fan unit can be easily lifted in and out.
2. Install the new bearing pedestal in the existing fan housing. This option is suitable if there is possibility that the shaft or bearing housing are damaged due to a bearing failure, and for companies that wish to replace the bearings themselves. Option 2 normally takes one man 5-7 hours to complete.
3. Replace the bearings in the existing bearing housing. This is the least expensive option, but takes the longest time to carry out, 8-10 hours for one man. Option 3 is suitable when the bearings are replaced as a preventive measure.

 **NOTE!** If the bearing pedestal has been damaged due to bearing failure, then option 2 (or 1) must be chosen.

3.2 Replacement tools

See figure 2. (1-3) The following tools are required for the different options.

3.2.1 Replacement Option 1

See figure 2(1). A normal tool set and a socket set are required.

Special tools

- Shortened 6 mm allen key.
- Shortened screw W7/16" x 7/8" to remove the transmission.
- A digital temperature meter with a surface probe is useful to check the bearing temperature.

3.2.2 Replacement Option 2

See figure 2(2). In addition to the above tools:

- A torque wrench with an action up to 200 Nm.
- Hook wrench for 0 65 mm are required.

Special tools

- Spanner for tightening a 065 mm nut.
- Spanner for holding.
- Straight gauge.
- Hooked gauged.

Some silicon-free sealant can be required.

3.2.3 Replacement Option 3

See figure 2(3). In addition to the above:

- External puller.
- Closing circlip pliers.
- Plastic mallet
- A block of wood (approximately. 50x75x500).
- A small amount of light oil is required.

Special tools

- Impact sleeve.
- A guide sleeve for correct bearing alignment.

3.3 Other service measures

Other service measures recommended during bearing replacement:

- Change drive-belts. Quantity and type as per the manual for VAC20 unit.
- Check the oil level in flow restrictor FR 160 and refill the damper, if necessary with ATF-oil as set out in the manual.
- Replace the flow restrictor FR 160 if the original restrictor is of an older model without an oil filled damper.

3.4 Replacement procedure:**WARNING! Risk of personal injury.**

Switch off and lock the maintenance switch or remove the main fuses before starting work.

NOTE! The assembly instructions below cover all three options. But only option 3 is described below since it is the most comprehensive. It is evident from the instructions which sections apply to options 1 and 2.

3.4.1 Dismantle the fan unit from the vacuum pump (Option 1, 2 & 3)

See figure 3. The fan unit, shaft and bearing pedestal should be removed from the vacuum unit. None of the options can be carried out without removing the fan from the unit. Release the fan by removing the enclosure from the top and sides, let the inlet side and the short side closest to the fan remain fitted. Release the fan by removing the enclosure from the top and sides, let the inlet side and the short side closest to the fan remain fitted.

1. See figure 3(1). Remove the flow restrictor from the fan outlet, figure 3(1).

NOTE! Do not turn the flow restrictor as oil can run out. Some units do not have a flow restrictor.

2. Loosen the clamp that holds the back flush valve on the fan inlet. Let the valve remain in position, figure 3(2).
3. Remove the bearing's thermal cut-out cable from the connection box, figure 3(3).
4. Some units have a thermal switch on the fan's outlet. Loosen the cable that runs to the connection box on the back flush valve. Let the cable remain connected to the connection box on the back flush valve, figure 3(4).
5. Remove the belt guard (not fitted to older models). Remove the belts by loosening the motor and sliding it towards the fan. Remove the belt pulley from the fan, figure 3(5).

NOTE! (Detailed instructions for removing the belt pulley are given in section 3.4.2. *Detailed instructions for removing the belt pulley.*)

6. Remove the four bolts that hold the bearing pedestal and the two bolts that hold the fan housing's lower section on the frame. Lift out the fan unit, figure 3(6).

3.4.2 Detailed instructions for removing the belt pulley

See figure 4. The belt pulley is a conical clamping sleeve model, i.e. the contact surface between the sleeve and the pulley is conical. Two screws pull the pulley onto the sleeve so that it grips around the shaft.

The pulley is removed by loosening the two allen screws and then inserting a bolt in the extractor hole. The sleeve and pulley slide a part and the sleeve's grip on the shaft is released.

NOTE! 4 and 6 grooved belt pulleys are removed differently as shown in figures 4(1-6).

1. Parts in a 4 grooved pulley. A standard 6 mm allen key is used to remove the pulley, figure 4(1).
2. One of the screws is oiled and threaded in the extractor hole. The pulley slides off the sleeve towards the inside. A light tap using a plastic mallet can be necessary, figure 4(2).
3. Parts in a 6 grooved pulley. A shortened 6 mm allen key and a shortened screw are required for dismantling, figure 4(3). See also section 3.2. *Replacement tools*,

4. Loosen the allen screws holding the pulley and sleeve together a few turns. Insert the shortened special screw, oiled, into the extractor hole, figure 4(4).
5. Remove the screw using the shortened allen key. The pulley should slide off the sleeve outwards, figure 4(5).
6. A puller extractor can be necessary if the pulley does not slide off the sleeve, figure 4(6). (Only 6 grooved.)

3.4.3 Dismantling the fan (Options 2 & 3)

1. See figure 5. Mark the fan casing halves' position in relation to each other with a pen and remove the outer casing half, figure 5(1).
2. Pry up the tongue on the lock washer, figure 5(2).
3. Use a hook wrench to loosen the nut. Extend the hook wrench if necessary using a pipe or the like; use the spanner to stop shaft movement, figure 5(3).
4. Mark the fan wheel "outer wheel" and remove it, figure 5(4).
5. Remove the key and spacer, figure 5(5).
6. Remove the screws that hold the intermediate casing and remove it, figure 5(6).
7. Remove the inner key and spacer, figure 5(7).
8. Loosen the screws and remove the inner fan casing, figure 5(8).

3.4.4 Replacing the bearing (Option 3)

See figure 6. Carry out bearing replacement in a clean and dry area. Use the tools described in these instructions. It is extremely important that no great force is applied to the bearing during fitting. Any damage to the bearing race will significantly reduce the new bearing's service life.

1. Fit the old locking nut on the shaft flush with the end of the shaft to protect the thread. Hit with the plastic mallet to remove the shaft, figure 6(1).
2. Remove the sealing washer from the fan bearing using a large screwdriver or crowbar. Remove the circlip using the circlip pliers, figure 6(2).
3. Insert the block of wood in the bearing pedestal and hit it using the plastic mallet so that the fan bearing slides out. Ensure the bearing is knocked out straight. The bearing's outer ring is free-running in the bearing housing with a very close tolerance. In some cases its possible to lift out the bearing by hand, but generally it needs to be lightly tapped for it to slide out. There should be a "curved" washer behind the bearing which needs to be removed, figure 6(3).
4. Insert the bolt in the shaft end and puller off the transmission bearing using a puller, figure 6(4).
5. Inspect the bearing journal on the shaft and in the bearing pedestal. Clean the journal using white spirit and a cloth. Remove any paint residue. If the bearing journal has been damaged, due to a bearing seizure, a new bearing pedestal must be fitted as per option 2, figure 6(5).
6. Start by fitting the inner bearing, the fan bearing, on the shaft Wipe of the protective grease from the bearing. Apply a little light oil, e.g. ATF oil, on the bearing journal, figure 6(6).

7. Turn the impact sleeve so that the inner surface faces the bearing when the sleeve is inserted on the shaft, figure 6(7).
8. Drive the bearing on the shaft. A “metallic noise” is heard when the bearing reaches the end position, figure 6(8).
9. Insert a new “curved washer” in the bearing pedestal, figure 6(9).
10. Apply a little oil to the bearing housing, figure 6(10).
11. Insert the guide sleeve into the transmission bearing housing, figure 6(11).
12. Insert the shaft in the bearing housing. The impact sleeve should now be turned so that the outer striking surface faces the bearing. Tap the bearing into the housing. The bearing’s outer ring is free-running in the bearing housing with a very close tolerance. Only a slight force is required to insert the bearing in its correct position against the curved washer, figure 6(12).
13. Fit the circlip, figure 6(13).
14. With the bearing pedestal bearing on the floor, in the guide sleeve, press the circlip and bearing down against the curved washer until the circlip snaps into its correct position, figure 6(14).

Ensure it has snapped in all the way round. This locks the bearing axially and the bearing’s outer ring, which is free-running in the bearing pedestal, is prevented from rotating in the bearing pedestal.

Let the guide sleeve remain in the other bearing housing to prevent the shaft from causing undue stress to the newly fitted bearing, figure 6(13).

Before the transmission bearing is fitted, apply a little oil on the bearing’s inner ring when the protective grease has been wiped off.

15. Remove the guide sleeve and insert the transmission bearing without the shaft entering the bearing. Turn the impact sleeve so that the inner surface faces the bearing, figure 6(15).
16. Figure 43. Fit the old nut flush with the shaft end. Place the shaft with the nut on a hard surface, preferably a concrete floor, figure 6(16).

(A soft resilient surface causes the shaft to vibrate when the transmission bearing is driven on. This means that the newly fitted fan bearing is exposed to extreme mechanical stress when the vibrations are transferred to the bearing pedestal.)

Drive the bearing onto the shaft. The bearing’s outer ring is free-running in the bearing housing with a very close tolerance, and therefore there will be no great force over the bearing when the inner ring is driven on the shaft with a forced fit. A metallic noise is heard when the bearing reaches its end position.

(During operations the belt tension stops the outer ring from rotating in the bearing housing. Due to changes in the temperature it is necessary that the transmission bearing can move axially in the bearing pedestal.)

17. Fit a new sealing washer outside the fan bearing. Carefully tap in the washer using a hammer if necessary, figure 6(17).
18. Then use the impact sleeve with the outer striking surface, to drive the washer in until it stops against a small heel inside the bearing pedestal, figure 6(18).

19. If the bearing pedestal has been fitted with a thermal fuses these should be replaced with the resettable thermal switches supplied in the kit, figure 6(19).

The bearing pedestal is now ready to be assembled with the fan.

3.4.5 Fitting the fan and bearing pedestal. (Opt 2 & 3).

See figure 7. A new or renovated bearing pedestal is assembled with the fan as follows:

1. Fit the inner fan casing onto the bearing pedestal with the outlet facing upwards! If any of the bolts have been damaged during dismantling there are number of new bolts in the kit. Ensure that any holes not used are sealed with silicon-free sealant, figure 7(1).
2. Fit the inner spacer, key and inner fan wheel, figure 7(2).
3. Check using the straight gauge that the distance between the fan wheel and casing is sufficient for free running, i.e. at least 3 mm. If not, increase the space with the 1 mm spacer supplied with the kit, figure 7(3).
4. Position the intermediate casing and fit the long spacer. Centre the intermediate casing around the spacer, figure 7(4).

Check the seal. If the original seal is undamaged and of the same type as the new seal supplied in the kit, it is not necessary to replace the seal. Otherwise the seal should be changed.

5. Tighten the casing when it is centred. A few extra nuts, bolts and washers are supplied in the kit, figure 7(5).
6. Fit the key and the outer wheel. Check using the gauge that the distance to the intermediate casing is at least 3 mm. If not, increase the space with the 1 mm spacer supplied with the kit, figure 7(6).
7. Fit the new locking washer and nut supplied in the kit, figure 7(7).
8. Prevent shaft movement by using a spanner. Using a torque wrench and the special spanner for the nut, tighten the nut to approximately. 195 Nm (140lb ft). Do not, under any circumstance, insert any object in the fan wheel to counteract movement as this will damage the wheel, figure 7(8).

Lock the nut. Correct the torque, up or down, until the tongue fits in the nut.

9. Centre and fit the outer fan wheel. Use the hook gauge to check the centred position before the casing is finally secured. First, check the seal as set out above, figure 7(9).

The fan unit is now ready for assembly in the vacuum unit.

3.4.6 Fitting the fan in the vacuum unit (Opt. 1, 2 & 3)

See figure 8. Secure the fan unit to the frame. Do not forget the screws that secure the lower section of the fan to the frame.

1. Connect the cable for the bearing's thermal cut-out in the connection box. The thermal cut-out now consists of reset table thermal switches, which replace the old thermal fuses, figure 8(1).
2. Some older models had a thermal fuse inserted in a tube in the fan outlet. This has been removed and should not be refitted. A protective cap is included in the kit and is inserted in the hole to seal it or, remove the tube and seal using a nut and bolt, figure 8(3).

3. The round thermal switch on the fan outlet, connected to the temperature control valve TAV50 MV, should be refitted and the cable connected. Note that the thermal switch should be recessed in a hole in the fan outlet. Some older fans may have the switch fitted to the surface, this should be changed, figure 8(3).
4. A unit fitted with anti-surge control ASC, does not have a thermal switch. If it should be fitted to the fan outlet on e.g. a reconditioned unit then the thermal switch should not be connected if ASC is fitted, figure 8(4).
5. Ensure that the flow restrictor's damper is filled to the correct level with ATF oil as per the instructions (MA15-001) supplied with the vacuum unit. It is recommended that you replace the flow limiter if it is of an older type that does not have a damper. Fit the flow restrictor so that its axle is parallel with the fan wheel, figure 8(5).

Refit the clamp that connects the back flush valve with the fan inlet.

6. Refit the belt pulley. Use the original spacers, but the new center screw and lock washer. First, tighten the sleeve and pulley together loosely. the sleeve should slide on the shaft, figure 8(6).
7. With the two screws still loose, tighten the centre screw to approximately. 40 Nm (29 lb ft). This applies the right axial force to the transmission bearing's inner ring. Now finally tighten the pulley on the sleeve using the two allen screws, figure 8(7).

(The 6 grooved pulley is tightened from the inside using the shortened allen key, 4 grooved pulley from the outside with a standard allen key.)

8. Replace the drive belts if they have not been changed recently. XPZ toothed belts are recommended in preference to SPZ V-belts, figure 8(8).
9. Align the transmission before the motor is finally tightened.
10. Refit the belt guard if previously fitted. The belt guard was introduced in 1995 and can be ordered separately if required.

3.4.7 Test running

Finally test run the unit. Check that no abnormal noise can be heard and that the temperature of the bearing pedestal does not exceed 100°C. After a few hours of operation the temperature should have fallen to 50-90 °C.

