

Air powered series

Ab216 - NE32, S50 wo/accessories

42121681

Original manual

EN MODEL SPECIFICATION AND SPARE PARTS

Model specification

Description: Ab216 - NE32, S50 wo/accessories

Model: 42121681

Code no.	Description	Qty.
43022001	NE32, S50	1
43120200	Absolute filter L=220 A=1.56m ² wo/perf.plate	1
43140010	Clamp f/cartr.filter M10 L=90 EI-Zn	1
43332001	Container S50 47l w/ecc fastners	1
43424001	Silo S50 w/rev air clean	1
43723001	Trolley S50 f/silo	1

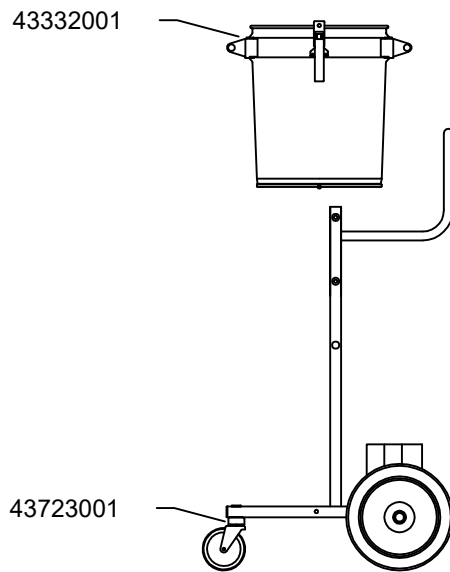
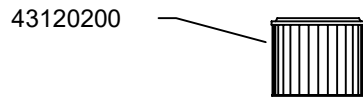
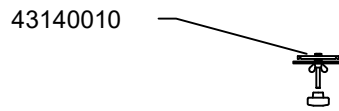
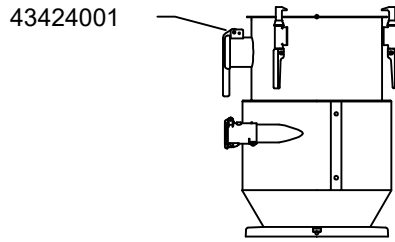
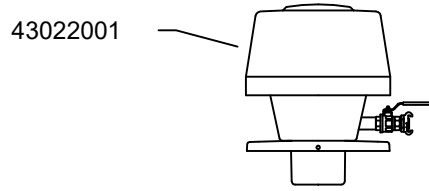



MAX 8 bar



S235JR(St37.2)

- 43904001
- 43904101
- 43904201

- 43904002
- 43904102
- 43904202

43903010

43909001

43909008

System 50

- 43610001
- 43610011 A4
-

System 200

- 43615001
- 43615011 A4
-

- 43621001
- 43621200 A4
-

- 43937006
- 43937007



43905020



43937010

System 50

- 43901052
- 43901050

System 200

- 43901053
- 43901051

43908003

	Vacuum producer	Compressed air consumption	Max. vacuum		Max. air flow	Noise level*	Ejector body
		Nm ³ /min	mmWC	-kPa	Nm ³ /hr	dB(A)	
<input type="checkbox"/>	NE22	1,0	2100	21	306	72,0	43905001
<input checked="" type="checkbox"/>	NE32	1,6	3100	31	342	74,0	43905002
<input type="checkbox"/>	NE42	2,2	4200	42	360	73,5	43905003
<input type="checkbox"/>	NE52	3,0	5200	52	342	75,5	43905004
<input type="checkbox"/>	NE56	2,7	2500	25	564	73,5	43905005
<input type="checkbox"/>	NE64	4,3	6800	68	330	77,0	43905006
<input type="checkbox"/>	NE66	4,1	3800	38	630	76,5	43905007
<input type="checkbox"/>	NE74	5,3	7800	78	318	75,0	43905008
<input type="checkbox"/>	NE76	5,4	4800	48	690	78,0	43905009
<input type="checkbox"/>	NE96	8,6	6800	68	660	78,0	43905011
<input type="checkbox"/>	NE56x2	5,4	2500	25	1128	76,5	43905005
<input type="checkbox"/>	NE96x2	17,2	6800	68	1320	79,0	43905011
<input type="checkbox"/>							

*Noise level - distance: 3 m - height: 1,1 m

(Air pressure 7 bar)



	Product number:	Area m ²	Max. temp. °C	Diameter mm	Height mm	Weight kg	BIA	EN 60335-2-69 / EN1822	Anti-static	Wash-able	End plate*
<input type="checkbox"/>	43110001	0,50	70	-	-	0,6	-	-	-	-	-
<input type="checkbox"/>	43110100	0,35	120	-	-	0,2	-	-	-	-	-
<input type="checkbox"/>	43110200	0,35	120	-	-	0,2	-	-	X	-	-
<input type="checkbox"/>	43110300	0,59	120	-	-	0,4	-	-	-	-	-
<input type="checkbox"/>	43110400	0,59	120	-	-	0,4	-	-	X	-	-
<input type="checkbox"/>	43120100	2,38	70	264	220	1,7	U,S,G,C	M	-	-	-
<input type="checkbox"/>	43130001	2,38	70	264	220	2,0	U,S,G,C	M	-	-	-
<input type="checkbox"/>	43130100	2,38	70	264	220	1,0	U,S,G,C	M	-	-	-
<input type="checkbox"/>	43130200	5,40	70	264	470	2,0	U,S,G,C	M	-	-	-
<input type="checkbox"/>	43130201	5,40	70	264	470	3,0	U,S,G,C	M	-	-	-
<input type="checkbox"/>	43130300	6,90	70	264	600	3,0	U,S,G,C	M	-	-	-
<input type="checkbox"/>	43130301	6,90	70	264	600	4,0	U,S,G,C	M	-	-	-
<input type="checkbox"/>	43130400	10,00	70	264	870	5,0	U,S,G,C	M	-	-	-
<input type="checkbox"/>	43130401	10,00	70	264	870	5,0	U,S,G,C	M	-	-	-
<input type="checkbox"/>	43130500	1,56	70	264	220	2,1	K1/K2	H13	-	-	-
<input checked="" type="checkbox"/>	43120200	1,56	70	264	220	2,0	K1/K2	H13	-	-	-
<input type="checkbox"/>	43130700	3,50	70	264	470	3,2	K1/K2	H13	-	-	-
<input type="checkbox"/>	43130702	3,50	70	264	470	4,0	K1/K2	H13	-	-	-
<input type="checkbox"/>	43130800	4,50	70	264	600	3,8	K1/K2	H13	-	-	-
<input type="checkbox"/>	43130801	4,50	70	264	600	3,0	K1/K2	H13	-	-	-
<input type="checkbox"/>	43130900	6,50	70	264	870	4,8	K1/K2	H13	-	-	-
<input type="checkbox"/>	43130901	6,50	70	264	870	6,0	K1/K2	H13	-	-	-
<input type="checkbox"/>	43120300	2,28	120	264	220	2,0	U,S,G,C	M	-	X	-
<input type="checkbox"/>	43120301	2,38	120	264	220	2,0	U,S,G,C	M	X	X	GS
<input type="checkbox"/>	43120303	10,00	120	264	87	4,0	U,S,G,C	M	X	X	-
<input type="checkbox"/>	43120304	2,38	120	264	220	2,0	U,S,G,C	M	X	X	A4
<input type="checkbox"/>	43120400	0,7	80	338	42	0,8	U,S,G,C	M	-	-	-
<input type="checkbox"/>											

* A2=AISI 304 / A4=AISI 316L / GS=Galvanized steel



S235JR(St37.2)

- 43999021
- 43999721 A4

- 43999031
- 43999531

- 43999003
- 43885001

- 43909003
- 43909103 A4
-

- 43625001
-

- 43907011
- 43907013
- 43907015

- 43907004
- 43907104

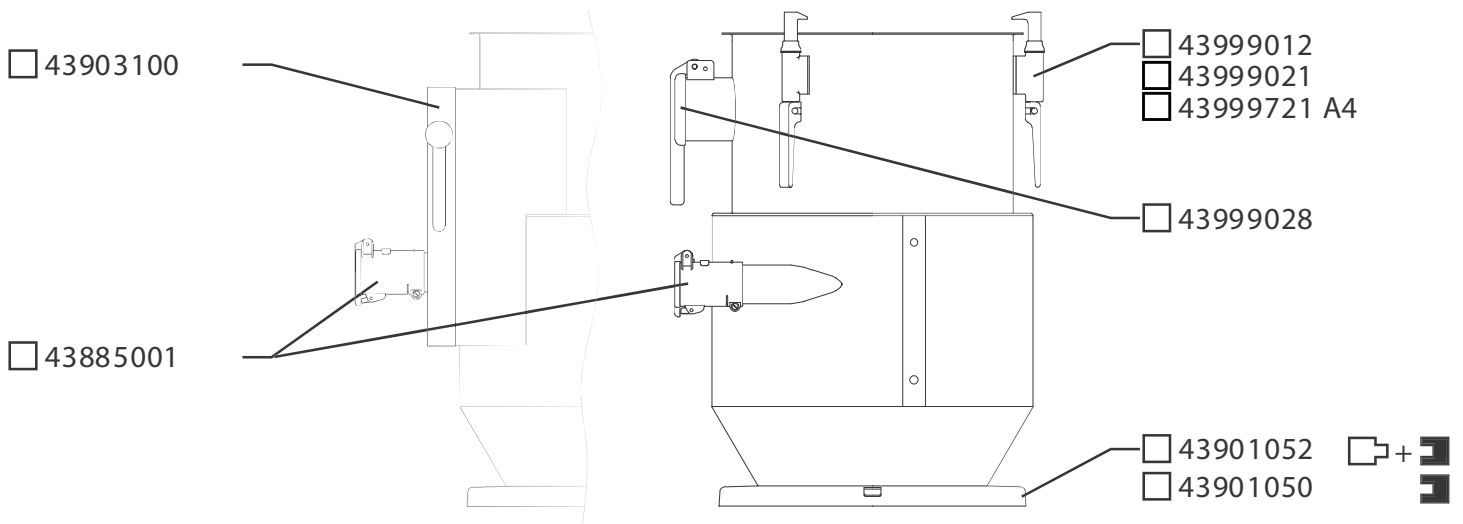



S235JR(St37.2)

